

TOP VIEW

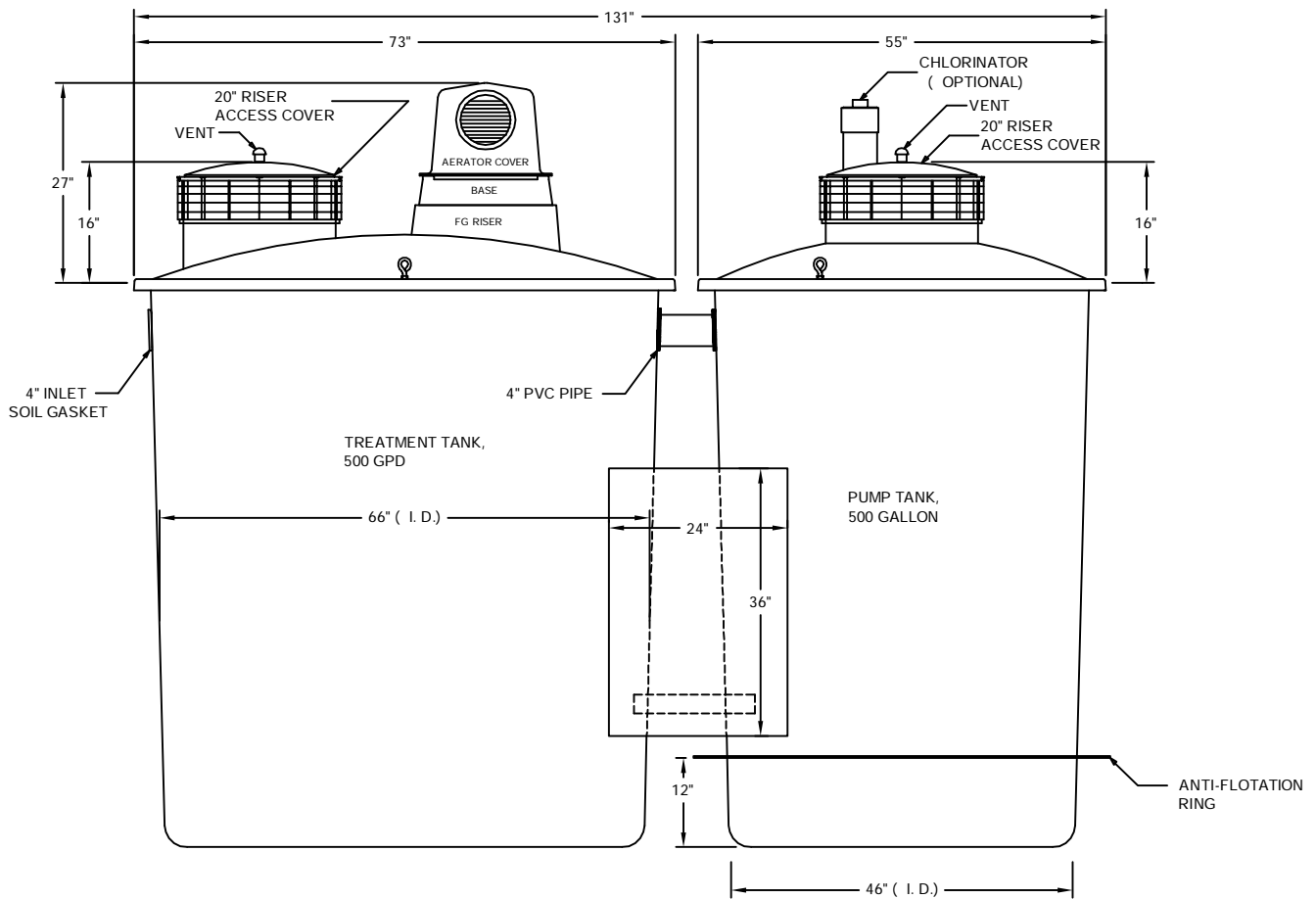

SIDE VIEW

ALL DIMENSIONS IN INCHES

<b>DESCRIPTION:</b>				
MODEL AS500 + 5 PUMP DUO WITH EZ TOP				
Treatment Capacity: 500 GPD		Flow Line Volume: 1000 GAL		
BOD Loading: 1.25 #/DAY				
DWG REF: D-TA-012	REV: 0	DATE: 11/10/04	SCALE: FULL	ENG: RD
<b>ECOLOGICAL TANKS, INC</b>		NO PART OF THIS DRAWING MAY BE REPRODUCED, STORED IN ANY RETRIEVAL SYSTEM OR TRANSMITTED IN ANY FORM OR BY ANY MEANS, ELECTRONIC, MECHANICAL, PHOTOCOPIING, RECORDING OR OTHERWISE WITHOUT THE PRIOR WRITTEN PERMISSION OF ECOLOGICAL TANKS, INC.		
2247 HWY 151 NORTH				
DOWNSVILLE, LA 71234				
318-644-0397 OFFICE 318-644-7257 FAX				