

ECOLOGICAL TANKS, INC.



Class I Wastewater Treatment Plants

OWNER'S MANUAL

US Patent #5549818

- Model AS500
- Model AS500-4+75
- Model AS600
- Model AS750
- Model AS1000
- Model AS1500

Concrete

Fiberglass

EZ Top

"Copyright Notice"

No part of this publication may be reproduced, stored in any retrieval system, or transmitted in any form or by any means, electronic, mechanical photocopying, recording, or otherwise without the prior written permission of Ecological Tanks, Inc.

Mfg. By

Ecological Tanks, Inc.

2247 Hwy 151 North

Downsville, LA 71234

PH (318)644-0397 *FAX (318) 644-7257



Certified to NSF/ANSI Standard 40

©2008

INTRODUCTION

All **Aqua Safe®** series models are certified based on provisions in NSF/ANSI Standard 40. The **Ecological Tanks, Inc., Aqua Safe®** model **AS500** has been tested by the Baylor University Department of Environmental Studies according to requirements listed in NSF/ANSI Standard 40, and meets or exceeds Class 1 effluent requirements.

Installation requirements may vary by state. Therefore, your wastewater treatment plant may contain auxiliary components with the treatment plant not furnished by **Ecological Tanks, Inc.** Included in this owner's manual is the **Aqua Safe®** model numbers **AS500, AS500-4+75, AS600, AS750, and AS1000** concrete and fiberglass series wastewater treatment plants.

State and/or local regulations govern the installation and use of individual aerobic wastewater treatment systems. All permits required by state and/or local regulations should be obtained prior to the **Aqua Safe®** plant installation.

It is the responsibility of the **end user** (owner) to see that the **Aqua Safe®** plant and associated auxiliary component items are installed in accordance with all applicable laws, regulations and guidelines in effect in your respective state. Please consult your local sanitarian or environmentalist prior to system installation.

AQUA SAFE WASTEWATER TREATMENT PLANT PROCESS DESCRIPTION

Ecological Tanks, Inc., Aqua Safe® series models numbers **AS500, AS600, AS750, and AS1000** are made with an outer mixing compartment and a center settling or clarifier compartment. They are in many ways similar to large township or municipality sewage treatment plants. They employ an extended aeration activated sludge process. This type of treatment depends primarily upon the use of air that is introduced by air passing from the aerator compressor to four air lines located around the perimeter of the aeration mixing compartment. As wastewater enters the aeration mixing compartment, simple hydraulic displacement is accomplished by the introduction of air which promotes the growth of aerobic organisms in much larger quantities than would occur naturally. These bacteria break down the organic solids in the wastewater. From the aeration mixing compartment, mixed liquid enters the cone shaped settling or clarifier compartment from the bottom. No mixing occurs in this quiet zone where solids separate from the liquid and settle to the bottom of the clarifier and re-enter the mixing compartment. The liquid that separates from the solids in the clarifier continue to flow upward to the discharge pipe.

The **Aqua Safe®** model **AS500-4+75** is a four compartment concrete tank configuration with a chlorination device. It is comprised of a forward 400 gallon pre-treatment tank, an aeration mixing zone, a settling or clarifier compartment and a rear 750 gallon flow line capacity pump tank compartment. Wastewater first enters the pre-treatment tank compartment of the plant, then gravity flows through a 4" SDR 35 PVC inlet to the aeration mixing zone. The mixed liquid next enters the clarifier compartment and continues to flow upward to the discharge pipe. From the plant's discharge pipe, the final effluent passes through a chlorination device into the pump tank compartment for storage and contact mixing. The treated and disinfected effluent is then safely discharged, via an application pump, to a surface spray, subsurface drip, low pressure dose, absorptive mound or other disposal area.

The result of the Aqua Safe process is a clear, odorless effluent discharge, which meets and exceeds state and national water quality standards.

AQUA SAFE RECOMMENDED PLANT INSTALLATION INSTRUCTIONS

1. Inspect entire treatment plant and component parts.

2. Select location of plant site which is accessible to the home sewer discharge line, at least ten (10) feet from the home foundation, in an area that will not receive vehicular traffic. Prepare an excavation site by digging a hole at least one (1) foot larger than the treatment plant and a depth that will allow for sufficient coverage leaving approximately three (3) inches of the inspection port to extend above normal ground level. The depth of the plant will be controlled by the depth of the building sewer outlet line plus the amount of proper fall required from the building outlet sewer line to the inlet invert of the plant. The prepared excavation should have a solid, level bottom that will eliminate plant settling. Additionally, the bottom of the excavated hole should be free of rocks or sharp objects. **Aqua Safe®** plants should be installed on a bed of sand on undisturbed soil to provide a solid flat base.

3. Carefully lower the concrete treatment plant in the excavation with a designed and tested spreader bar or lifting device. The inlet line should slope down toward the plant and the outlet line should slope down away from the plant. The plant should be level to within one (1) inch, edge to edge. **Aqua Safe®** wastewater treatment plants should only be connected to properly trapped and vented plumbing systems in compliance with state and local plumbing codes.

4. Position the inlet and outlet lines and make the necessary connections. Clean-outs should be installed at building sewer tie-in, any changes in direction of flow and at maximum intervals of seventy (70) feet when using four (4) inch piping. The inlet line should be inserted and glued into the inlet elbow and the discharge line should be inserted and glued into the outlet coupling. Open the inspection port on top of the plant

and make sure the discharge tee assembly is level and centered in the clarifier prior to connecting discharge piping. Fill the tank with water to the point of flowing discharge before backfilling. Backfill evenly around the plant, up to the bottom of the inlet and

outlet piping, taking care not to damage the tank or dislodge the piping. Backfill material must be void of rocks, gravel, heavy clay or any type of material which might damage the tank.

5. The aerator compressor must be installed in a well ventilated, relatively clean and dry location. Install the aerator compressor on the treatment plant's tank top or at a remote location no more than one hundred (100) feet from the treatment plant. The aerator compressor is supplied complete with all discharge fittings. Install 3/4" Sch. 40 PVC piping (supplied by others) between the aerator and treatment plant. A minimum of twelve (12) inches ground cover is recommended over the 3/4" Sch. 40 PVC air piping.

6. The electrical control for the aerator compressor, visual and audible alarms for aerator failure and high water conditions are contained in a weather proof enclosure. It may be installed in any above ground area where the alarms are easily noticed by the occupants. It is recommended that the control box be at least six (6) inches above ground level and in view of the aerator compressor. All electrical wiring should be installed by a qualified person and must comply with NFPA 70, 1999, National Electrical Code. All electrical components not supplied must comply with U.L. Standards.

7. Install electrical wiring (provided by others) to interconnect the aerator compressor and alarms to the electrical control panel. A minimum of twelve (12) inches of ground cover is recommended over underground electrical conduit and wiring.

8. The aerator compressors used on **Aqua Safe®** wastewater treatment plants run continuously. They provide relatively quiet, energy efficient operation. Once properly connected, the electrical control box is to be closed. Operate the aerator compressor by placing the on/off electrical circuit (provided by others) in the "ON" position.

9. Turn on aerator compressor and check all air piping and fittings for leaks. This can be accomplished by preparing a saturated solution of soap and water and applying to entire run of pipe and fittings. If a leak is detected, effect repairs.

10. Carefully backfill all underground lines and the rest of the plant's excavation in a manner which will not cause damage to the completed installation.

11. The **Aqua Safe®** plant is ready to receive incoming sewage.

AQUA SAFE PLANT START UP

Initially the **Aqua Safe®** wastewater treatment plant is filled with clean water, usually from an owner's water supply. As stated in the installation instructions, once all proper connections have been completed and it is filled with water and the aerator turned on, the system is now in operation.

For the treatment plant to be biologically stable, it will take from four (4) to twelve (12) weeks after first using the plant to develop a population growth of microorganisms (bacteria). It is these bacteria which make the treatment system operate.

OWNER MAINTENANCE CARE AND OPERATION INSTRUCTIONS

Aqua Safe® home wastewater treatment plants have been designed and built by **Ecological Tanks, Inc.**, to provide long term, reliable and cost efficient service. Our treatment plants will operate with a minimum amount of attention.

If service is required, reference the system's DATA PLATES located on the **Aqua Safe®** control panel or aerator compressor for the plant's model number, the name, address and phone number of the local service person that can provide service. The following procedures should be performed on a routine basis to insure proper plant operation:

DAILY: Check warning light and audible alarm located on the plant's control panel for air supply malfunction or in system high water indication. If an alarm on condition is observed, it is an indication of malfunction. First check the electrical circuit providing power to the system to insure the circuit is closed. Check the aerator compressor to be sure it is operating. Check for over heating, excessive vibrations and unusual noises. If an aerator compressor failure is observed, call your service provider for service. After a power outage, an alarm condition may exist. Should an alarm remain on for more than thirty (30) minutes after power is restored, you should call your local service provider to report the alarm.

WEEKLY: Check the treatment plant for offensive odor. If present, call for service.

PERIODICALLY: Check and clean the air filter on aerator compressor. Rinse with warm water to clean if necessary. Make sure filter is dry and re-install on aerator compressor.

RECOMMENDED: Frequency of solids removal is no more often than every two (2) to five (5) years. Determination of the need for pumping can be made only by a trained service person by testing the tank contents and/or effluent.

WARNING - Hydraulic displacement and tank flotation may occur whenever tanks are pumped. Upon completion of pumping, tank **must** be refilled with water. Additionally,

care should be taken not to damage internal component parts. A certified **Aqua Safe®** service technician should oversee tank pumping.

OWNER'S RESPONSIBILITY

It is the *owner's responsibility* to operate the **Aqua Safe®** wastewater treatment plant to the best of their ability. To keep maintenance to a minimum and insure high effluent quality, the following items should not be permitted to enter the treatment plant:

1. Strong disinfectants or bleaches, other than small amounts used in day to day house cleaning and laundries. Recommended detergents are low-sudsing, low phosphates and biodegradable. Recommended cleaning products are non-chlorine, non-toxin, non-corrosive and biodegradable. Anti-bacteria soaps should be avoided.
2. Backwash discharge from any type of water softeners.
3. Citrus products, coffee grounds, chemical wastes, paint or paint thinners, oils or grease (such as used cooking grease), pet shampoo, pet dip disinfectant, pesticides, herbicides, automotive fluids or any other toxins.
4. Disposable diapers, tampons, sanitary napkins, large quantities of paper products, tobacco products, or similar items. Home brewery waste, strong medicines and antibiotics.
5. Waste material from a garbage disposal is not recommended without the use of a trash trap or pretreatment tank preceding the **Aqua Safe®** plant. Food waste represents additional loading the aerobic treatment unit would have to digest, increasing pump out intervals.
6. The **Aqua Safe®** wastewater treatment plant is designed for the treatment of **domestic wastewater** and nothing else should go into it.

During extended periods of intermittent or non-use, such as vacation time, the aerobic bacteria inside the plant will decrease due to no food in the form of incoming wastewater. The treatment plant will become biologically stable again soon after the resumption of normal loading. The aerator compressor should be left on during periods of vacation time. During extended periods of absolute non-use (3 months or longer) the aerator compressor should be removed, cleaned and stored with the compressor's inlet and outlet sealed. Additionally, the air line piping should also be capped to prevent debris from entering air distribution system.

The **Aqua Safe®** plant will not perform to its fullest capabilities if subject to hydraulic overloading. This condition exists whenever excessive water, above the plants designed treatment capacity, is allowed into the plant. Leaking plumbing fixtures or excessive water use may cause this condition. Hydraulic overload may also occur on wash days, when multiple loads of laundry are washed in succession.

Ecological Tanks, Inc. is not responsible for the infield operation of our plants. The proper operation of this wastewater treatment plant depends upon proper organic and hydraulic loading of the plant. We cannot control the loading of substances in our plants that may upset its biological balance. We can only provide a complete owner's manual which outlines materials that should be kept out of the treatment plant. User operation instructions must be followed or warranties are subject to invalidation.

WARNING! Ants and rodents are destructive to the mechanical and electrical equipment on wastewater treatment plants. Care should be taken to prevent infestation of ants near the plant. Damage or destruction of mechanical or electrical equipment by ants or rodents is not covered under manufacturers' warranty.

Any and all safety requirements such as the electrical wiring, blower operation or plant discharge concerning the owner, their families, friends, or guests is the sole liability of the owner (see warranty and service policy).

The electrical control panel contains a schematic for the system. However, the electrical control panel is sealed and contains no user serviceable parts. Test and alarm silence switches are located on the outside of control panel.

WARNING! Service to the electrical control panel by a non-qualified person may result in an electrical shock hazard resulting in serious injury or death. If service is required contact your local authorized installer representative or maintenance provider.

Many states already require the use of a chlorination unit behind all mechanical treatment plants for total effluent disinfection prior to final discharge. **Ecological Tanks, Inc.** recommends the use of a disinfection device behind its mechanical plants for total effluent disinfection prior to final discharge.

SOURCES FOR OBTAINING REPLACEMENT PARTS OR COMPONENTS

Replacement parts or components may be obtained from your local installer or from **Ecological Tanks, Inc.**, 2247 Highway 151 North, Downsview, LA 71234.

*Office: 318-644-0397 *Fax: 318-644-7257 *E-Mail: aquasafe@bayou.com

LINEAR AERATOR COMPRESSOR PARTS LIST ALL TREATMENT PLANT MODELS HiBlow/HP

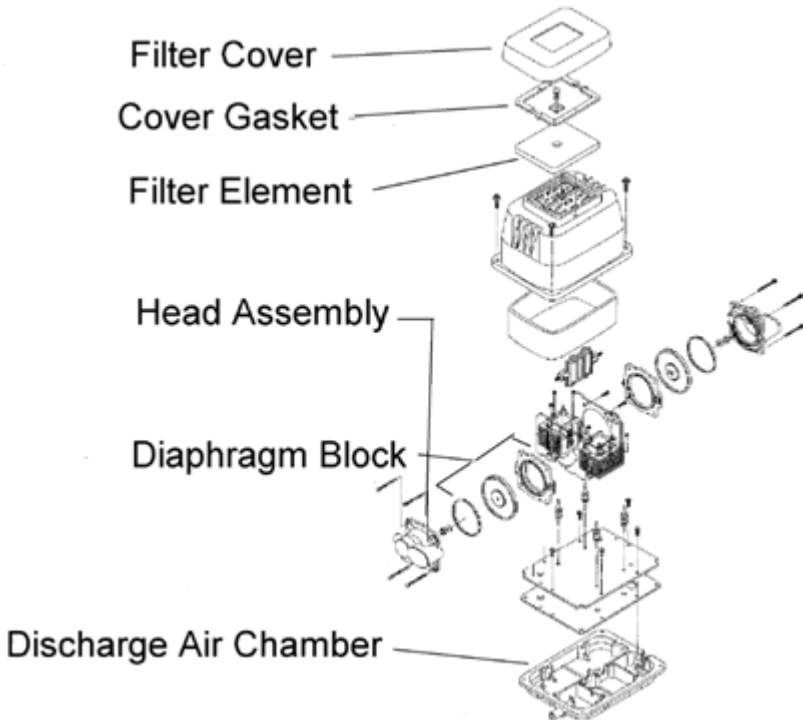

INITIAL SERVICE POLICY

The local dealer/installer from whom you purchased your **Aqua Safe®** wastewater treatment plant is responsible for routine inspections for the first two years from the original date of installation. The plant will be checked for proper operation at each inspection. If a problem exists, service will be performed at no charge to the owner unless the required maintenance is not warranty related. These service call/inspections shall include at least four inspections over the two year period and shall include the following:

1. Adjustment of the electrical control, if applicable, and servicing of the mechanical component parts to ensure proper function.
2. An effluent quality inspection consisting of a visual check for color, turbidity, scum overflow, and an examination for odors.
3. Immediate notification to the owner/warrantee in writing of any improper observation which cannot readily be repaired. This notification will or shall advise said owner of the problem, if it is covered by warranty and estimated date for correction of said problem.

Pumping of sludge build up from the treatment plant, if necessary, **IS NOT INCLUDED** in the initial service policy.

An annually renewable service policy affording the same coverage as the initial service policy is available. Consult your local dealer for pricing information.

LIMITED WARRANTY

Ecological Tanks, Inc., Aqua Safe® (hereinafter identified as manufacturer) warrants each aerobic wastewater treatment plant to be free from defects in workmanship and materials from the date of installation by an authorized dealer/installer for the following periods: Manufacturer warrants system aerator for a limited, prorated 5 year period as follows: First two years - 100%, 2nd to 3rd year - 75%, 3rd to 4th year 50% and 4th to 5 year period 25% of manufacturers list price. Third, fourth and fifth year limited prorated portion of this warranty applies only if system owner carries a continuous maintenance policy in full effect and **proof** is provided with return. AS1000 and AS1500 aerators **only are warranted for two (2) years**. Electrical controls, float switches, and application pumps are warranted for two (2) years. Manufacturer warrants fiberglass tanks to be free from defects in material and workmanship for a limited period of 5 years, concrete and metal tanks: limited 2 years from date of installation. When properly installed and **registered** with the manufacturer, the manufacturer's sole obligation under this **limited warranty** is as follows:

To repair or exchange any components, F.O.B. factory, that in the manufacturer's judgment is defective, provided that said component part has been paid for and is returned through an authorized dealer, prepaid. The warrantee must specify the nature of the defect in writing to the manufacturer. The **limited warranty** makes no provision for any informal dispute settlement agreement.

The **limited warranty** does not cover any aerobic wastewater treatment plant that has not been properly installed, damaged due to altered or improper wiring or overload protection, flooded by any external means, disassembled by any unauthorized person, filled with anything other than normal household wastewater or damaged by an act of nature. The **limited warranty** does not cover damages or defects caused by ants, insects or rodents to any component part of the aerobic wastewater treatment plant.

No warranty is made as to the field performance of any system. The **limited warranty** applies only to the aerobic wastewater treatment plant itself and does not include any of the purchaser's plumbing, drainage and/or disposal system, house wiring or installation of the plants.

The manufacturer reserves the right to replace any component part covered under this **limited warranty** with a component part, which in manufacturer's judgment is equivalent to the part replaced. The manufacturer claims no responsibility for any delays or damages caused by defective components or materials which cause losses incurred by interruption of service or for repairs or replacements of component parts covered by the **limited warranty**.

**MANUFACTURER'S WARRANTY REGISTRATION
CERTIFICATE**

It is the **authorized dealer/installer's responsibility** to fill out the registration certificate and mail it **within 30 days** of installation to the address below. The owner/purchaser should verify that this is done to insure proper registration for warranty purposes.

**ECOLOGICAL TANKS, INC.
2247 HIGHWAY 151 NORTH, DOWNSVILLE, LA 71234
OFFICE: 318-644-0397 FAX: 318-644-7257**

**PLEASE PRINT
AQUA SAFE PURCHASER'S RECORD**

Serial# _____ Model# _____
Installer's Name _____ Installation Date _____
Mailing Address _____ Phone _____
City, State, & Zip _____
.....

AQUA SAFE INSTALLER'S RECORD

Serial# _____ Model# _____
Owner's Name _____ Installation Date _____
Physical Address _____ Phone _____
City, State, & Zip _____
.....

**AQUA SAFE REGISTRATION CERTIFICATE
(Must be returned to manufacturer)**

Serial# _____ Model# _____
Owner's Name _____ Installation Date _____
Physical Address _____ Phone _____
City, State, & Zip _____
Dealer's Name _____ Phone _____
Mailing Address _____
City, State, & Zip _____
Installer's Name _____ Phone _____
Mailing Address _____
City, State, & Zip _____