

ECOLOGICAL TANKS, INC.

**AQUA  SAFE** ®

“The standard by which the performance of other units is compared”®

## Class I Wastewater Treatment Plants

# Installation, Operation, Maintenance and Trouble-Shooting Manual for Distributors, Installers, and Maintenance Providers

### MODELS

AS500	AS600	AS750	AS1000	AS1500
AS500EZ	AS600EZ	AS750EZ	AS1000EZ	AS1500EZ
AS500-CU	AS600-CU	AS500-3DUO	AS600-3DUO	AS500-P5CU
AS500+5DUO	AS500+5PRE	AS500-4+75	AS500+5TRIO	
AS500+75TRIO				

### “Copyright Notice”

No part of this publication may be reproduced, stored in any retrieval system, or transmitted in any form or by any means, electronic, mechanical, photocopying, recording, or otherwise without the prior written permission of Ecological Tanks, Inc.



**Mfg. By**  
**Ecological Tanks, Inc.**  
**2247 Hwy 151 North**  
**Downsville, LA 71234**  
**PH (318) 644-0397 \* FAX (318) 644-7257**

## I. INTRODUCTION

**Ecological Tanks, Inc.** was founded in 1994 by people with combined experience in installation, pre-casting and the building industry. At **Ecological Tanks, Inc.** our main goal is to provide products to professionals engaging in the business of distributing, installing and servicing home wastewater treatment plants. To continue our service, we have dedicated ourselves to manufacturing versatile products to simplify the task of installation and maintenance. This will include all-in-one aerobic systems, the first one box control for the operation of pumps and compressors, unique up-size controls and other products that are first in the on-site sewage industry. With this unique diversity and know how, we can provide the help you need with your on-site sewage treatment business.

**Ecological Tanks, Inc.** Model **AS500**, and larger, wastewater treatment plants have been tested by Baylor University Department of Environmental Studies according to requirements listed in NSF/ANSI Standard 40 and meets or exceeds Class 1 plant characteristic requirements.

Some states require the use of a trash trap independent of this test. **Ecological Tanks, Inc.** recommends strongly the use of a trash trap or pre-treatment tank, especially in all cases where a garbage disposal is being used or may be used. Additionally, **Ecological Tanks, Inc.** strongly recommends the use of a trash trap when using sprinklers, drip systems, or pressure dosing as a means of effluent disposal. A minimum recommended size for a trash trap is one-half the daily rated capacity of the unit. This recommendation enables enough capacity to store non-biodegradable materials over an extended period of time (several years) to minimize pumping requirements and overall maintenance on sprinkler, drip and dosing effluent disposal systems. This size is also small enough not to interfere substantially with the aerobic performance of the unit or to raise cost excessively. For purposes of the unit certification, a trash trap is treated as an approved upgrade.

## II. AQUA SAFE® WASTEWATER TREATMENT PLANT PROCESS DESCRIPTION

**Aqua Safe®** series models of wastewater treatment plants are made with an outer mixing compartment and a center settling or clarifier compartment. They are in many ways similar to large township or municipality sewage treatment plants. They employ an extended aeration, activated sludge process. This type of treatment depends primarily upon the use of air that is introduced by air passing from the aerator compressor to four air lines located around the perimeter of the aeration mixing compartment. As wastewater enters the aeration mixing compartment simple hydraulic displacement is accomplished by the introduction of air which promotes the growth of aerobic organisms in much larger quantities than would occur naturally. These bacteria break down the organic solids in the wastewater. From the aeration mixing compartment, mixed liquid enters the cone shaped settling or clarifier compartment from the bottom. No mixing occurs in this quiet zone where solids separate from the liquid and settle to the bottom of the clarifier and re-enter the mixing compartment. The liquid that separates from the solids in the clarifier continue to flow upward to the discharge pipe.

The **Aqua Safe®** models **AS500**, **AS500EZ**, **AS600**, **AS600EZ**, **AS750**, **AS750EZ**, **AS1000**, **AS1000EZ**, **AS1500** and **AS1500EZ** (Figures 1 - 3) are round tank configurations comprised of an aeration mixing compartment and a center clarifier compartment.

The **Aqua Safe®** models **AS500-3 Duo** and **AS600-3 Duo** (Figure 4) are a fiberglass round tank configuration comprised of an aeration mixing compartment, a center settling or clarifier

compartment and a 300 gallon attached pump tank with optional chlorination device and effluent filter. Wastewater first enters the aeration mixing zone. The mixed liquid next enters the clarifier compartment and continues to flow upwards to the discharge pipe. From the plant's discharge pipe, the final effluent passes through a chlorination device and the pump tank effluent filter into the pump tank compartment for storage and chlorine contact mixing. The treated and disinfected effluent is then safely discharged, via an application pump, to a surface spray, overland flow or other disposal area.

The **Aqua Safe®** models **AS500CU** and **AS600CU** (Figure 5) are fiberglass round tank configurations comprised of an aeration mixing compartment and a center clarifier compartment. Additionally, they both have an attached 68 gallon chlorine contact tank with a chlorination device.

The **Aqua Safe®** model **AS500-P5CU** (Figure 6) is a four compartment fiberglass tank configuration. It is comprised of a forward 500 gallon pre-treatment tank, an aeration mixing zone, a settling or clarifier compartment and a 68 gallon chlorine contact tank with a chlorination device. Wastewater first enters the pre-treatment tank compartment of the plant, then gravity flows through a 4" SDR 35 PVC inlet to the aeration mixing zone. The mixed liquid next enters the clarifier compartment and continues to flow upward to the discharge pipe. From the plant's discharge pipe, the final effluent passes through a chlorination device into the chlorine contact tank. The treated and disinfected effluent is then safely discharged in the disposal area.

The **Aqua Safe®** model **AS500 + 5 Duo** (Figure 7) is a three compartment fiberglass tank configuration. It is comprised of a forward 500 gallon pre-treatment tank, an aeration mixing zone and a settling or clarifier compartment. Wastewater first enters the pre-treatment tank compartment of the plant, then gravity flows through a 4" SDR 35 PVC inlet to the aeration mixing zone. The mixed liquid next enters the clarifier compartment and continues to flow upward to the discharge pipe.

The **Aqua Safe®** models **AS500 + 5 Trio** (Figure 8) and **AS500 + 75 Trio** (Figure 9) are four compartment fiberglass tank configurations with a chlorination device. They are comprised of a forward 500 gallon pre-treatment tank, an aeration mixing zone, a settling or clarifier compartment and a rear pump tank compartment. Model **AS500 + 5 Trio** has a pump tank flow line capacity of 500 gallons and model **AS500 + 75 Trio** has 750 gallons. Wastewater first enters the pre-treatment tank compartment of the plant, then gravity flows through a 4" SDR 35 PVC inlet to the aeration mixing zone. The mixed liquid next enters the clarifier compartment and continues to flow upward to the discharge pipe. From the plant's discharge pipe, the final effluent passes through a chlorination device into the pump tank compartment for storage and contact mixing. The treated and disinfected effluent is then safely discharged, via an application pump, to a surface spray, subsurface drip, low pressure dose, absorptive mound or other disposal area.

The **Aqua Safe®** model **AS500+5 Pre** (Figure 10) is a three compartment concrete tank configuration. It is comprised of a forward 500 gallon pre-treatment tank, an aeration mixing zone and a settling or clarifier compartment. Wastewater first enters the pre-treatment tank compartment of the plant, then gravity flows through a 4" SDR 35 PVC inlet to the aeration mixing zone. The mixed liquid next enters the clarifier compartment and continues to flow upward to the discharge pipe.

The **Aqua Safe®** model **AS500-4+75** (Figure 11) is a four compartment concrete tank configuration with a chlorination device. It is comprised of a forward 400 gallon pre-treatment tank, an aeration mixing zone, a settling or clarifier compartment and a rear 750 gallon flow line capacity pump tank compartment. Wastewater first enters the pre-treatment tank compartment of the plant, then gravity

flows through a 4" SDR 35 PVC inlet to the aeration mixing zone. The mixed liquid next enters the clarifier compartment and continues to flow upward to the discharge pipe. From the plant's discharge pipe, the final effluent passes through a chlorination device into the pump tank compartment for storage and contact mixing. The treated and disinfected effluent is then safely discharged, via an application pump, to a surface spray, subsurface drip, low pressure dose, absorptive mound or other disposal area.

The results of the **Aqua Safe®** process are a clear, odorless effluent discharge, which meets and exceeds state and national water quality standards.

# Aqua Safe Flow Diagram

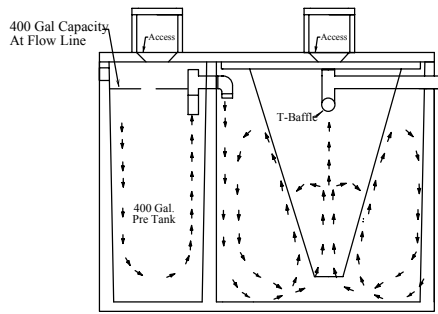

AS500 + 5 Pre

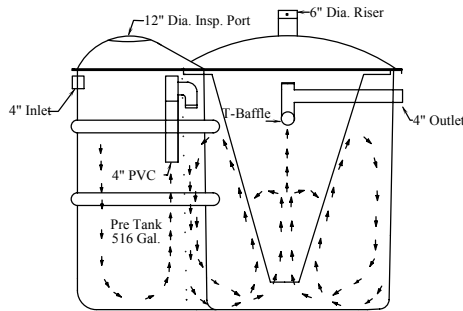

AS500 - 5 Pre

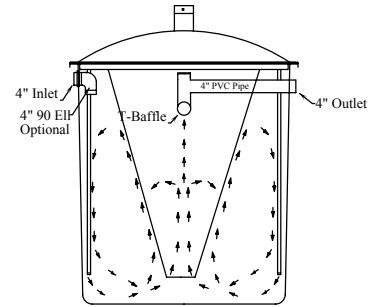

AS500, AS600, AS750, AS1000, AS1500

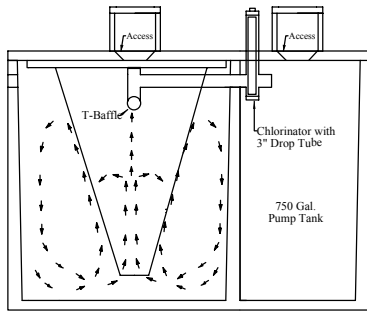

AS500 + 5 Pump

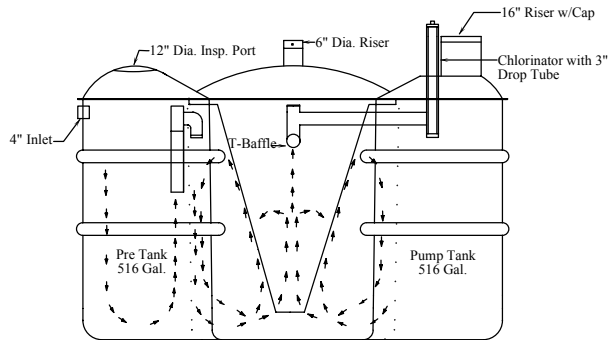

AS500 5+5

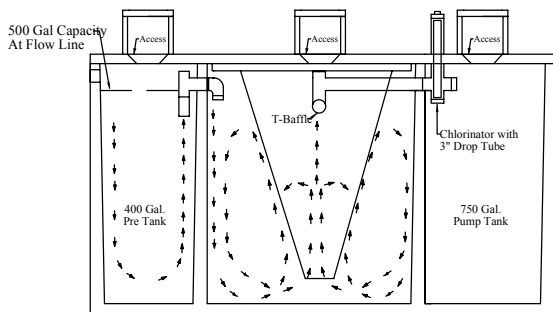

AS500 4+75

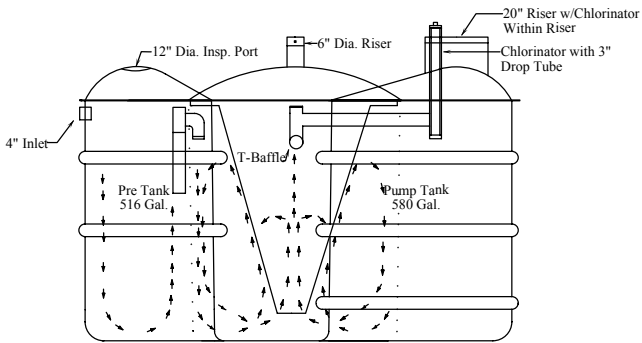

AS500 5+5 E

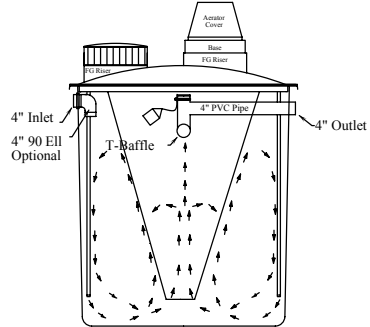

AS500, AS600, AS750, AS1000, AS1500  
EZ Models

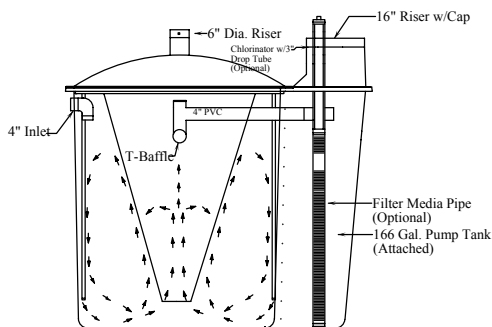

AS500-166

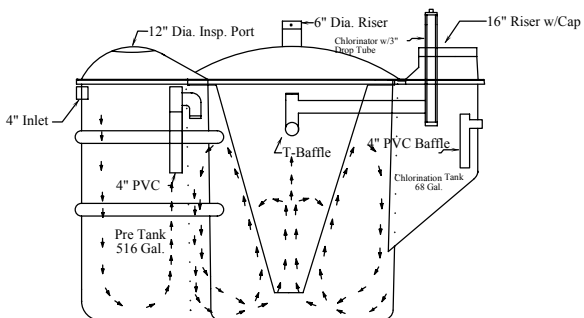

AS500 - P5CU

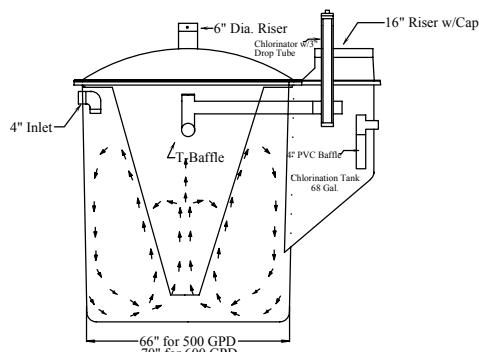

AS500 - CU

# AQUA SAFE® PRODUCT SPECIFICATIONS

## INDIVIDUAL HOME WASTEWATER TREATMENT PLANT

### MODELS AS500, AS600, AS750, AS1000, & AS1500 Including EZ Models

	A.S. 500	A.S. 600	A.S. 750	A.S. 1000	A.S. 1500
Treatment Capacity	500 GPD	600 GPD	750 GPD	1000 GPD	1500 GPD
Volumetric Capacity	1000 GAL.	1190 GAL.	1516 GAL.	2008 GAL.	2918 GAL.
Aeration Zone Capacity	848 GAL.	1000 GAL.	1288 GAL.	1706 GAL.	2349 GAL.
Clarifier Capacity	152 GAL.	190 GAL.	228 GAL.	302 GAL.	569 GAL.
BOD <sub>5</sub> Loading	1.25 #/DAY	1.50 #/DAY	1.85 #/DAY	2.50 #/DAY	3.75 #/DAY
Aerator-Aqua Safe Compressor	ASC2532	ASC3342	ASC3352	ASC5082	ASC7510

### DESIGN COMPONENTS AND MATERIALS

Aeration Tank & Cover ..... fiberglass or concrete  
 Clarifier ..... polyethylene or fiberglass  
 Compressor Housing..... polyethylene, fiberglass, or concrete

### PARTS LIST

Aeration Tank Fiberglass or Concrete..... item #1  
 Clarifier Fiberglass..... 2  
 Air Distribution System ..... 3  
 Access Cover 20" Polyethylene or Concrete ..... 4  
 Discharge Piping Assembly ..... 5  
 Compressor Housing..... 6

	DIMENSIONS	
MODEL	A (I.D.)	B (HEIGHT)
AS500	5'6"	6'4"
AS600	6'0"	6'4"
AS750	6'9"	6'4"
AS1000	6'9"	8'2"
AS1500	8'2"	8'2"

# AS500, AS600, AS750, AS1000 & AS1500

## with Poly Riser ECOLOGICAL TANKS, INC

### Individual Home Wastewater Treatment Plant

EZ Top Optional

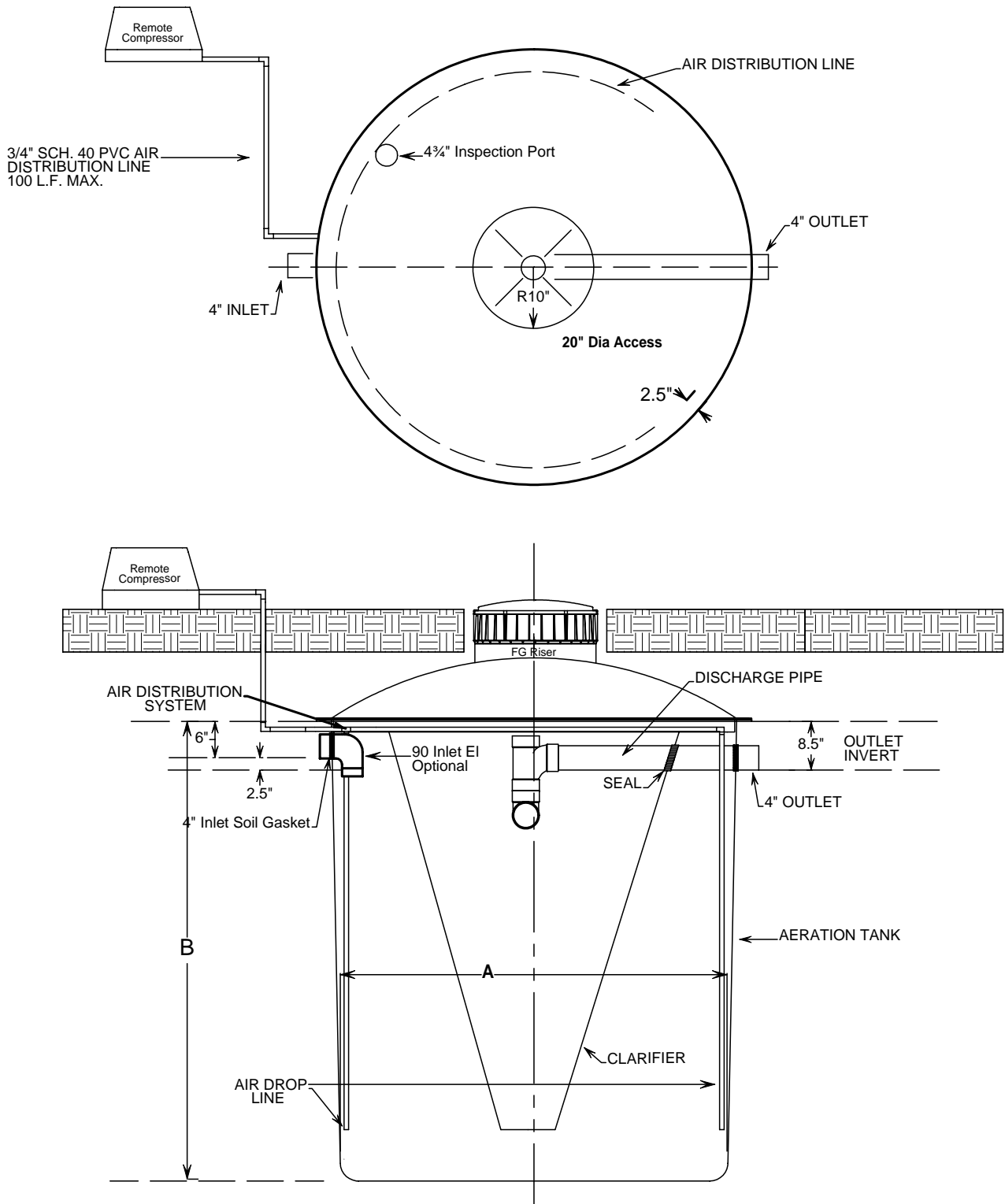

# Aqua Safe AS 500 - 1500 With EZ Top

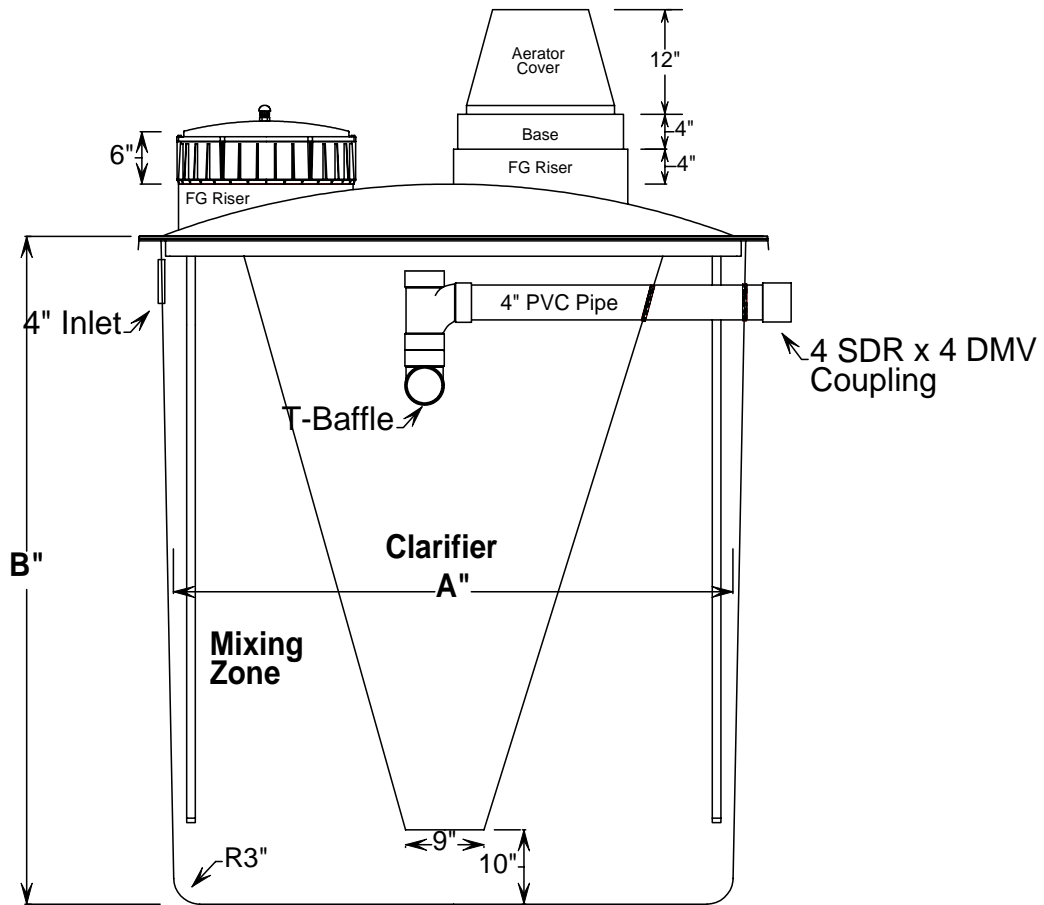
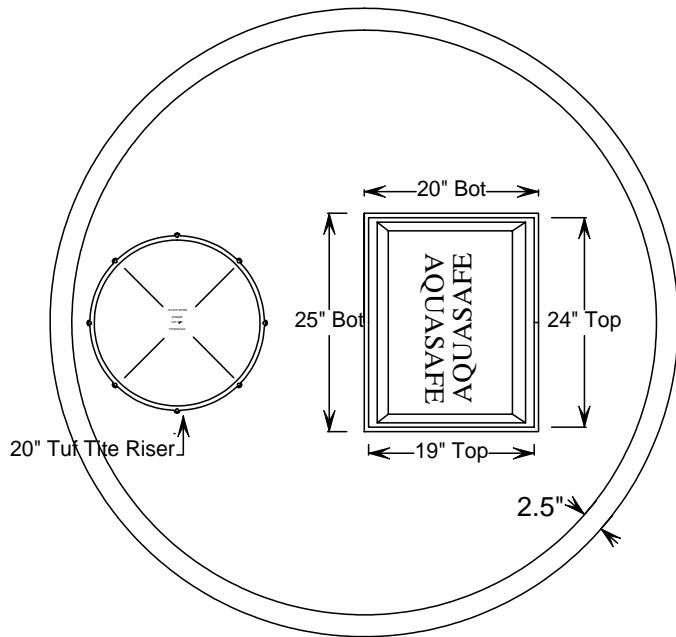

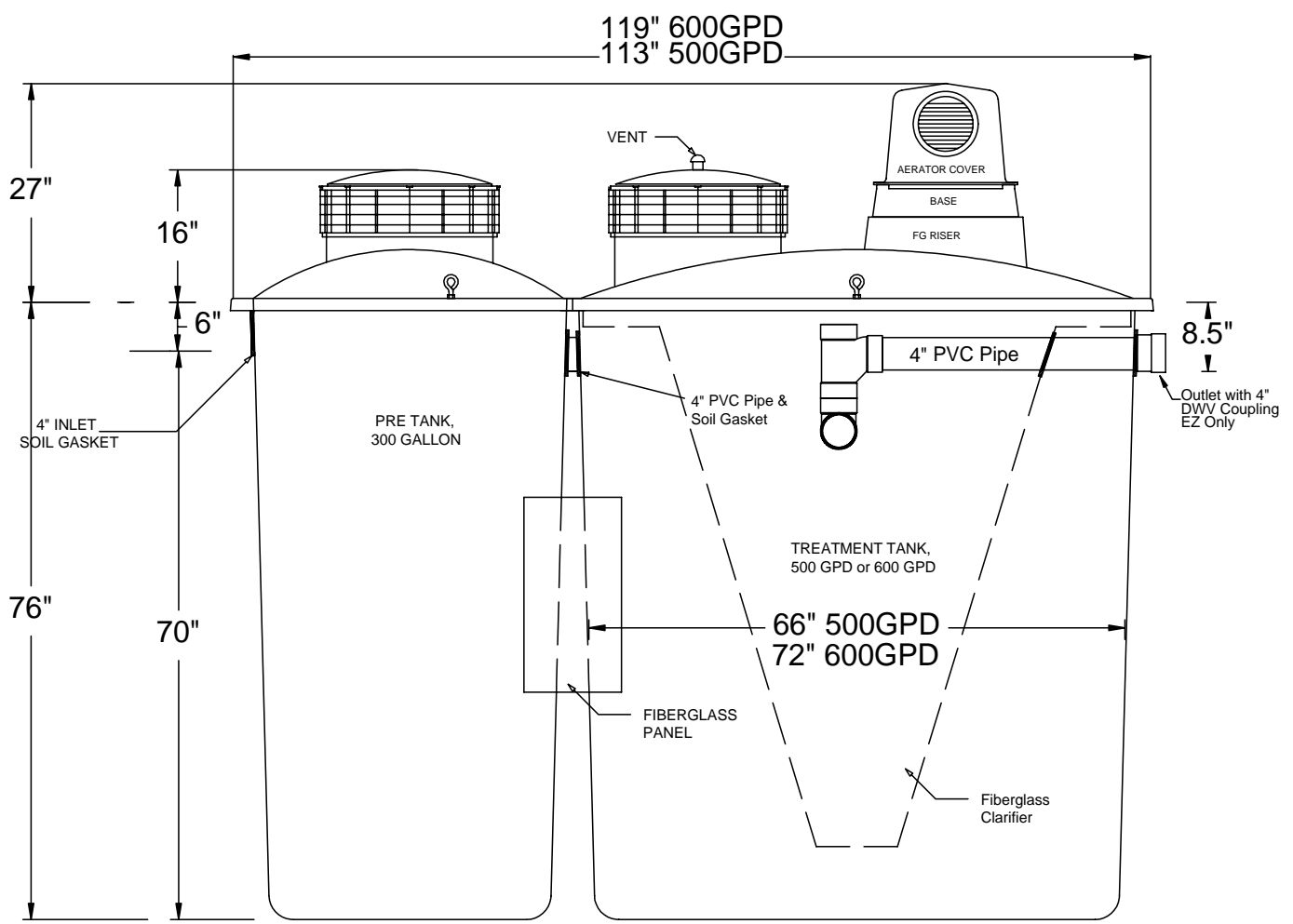
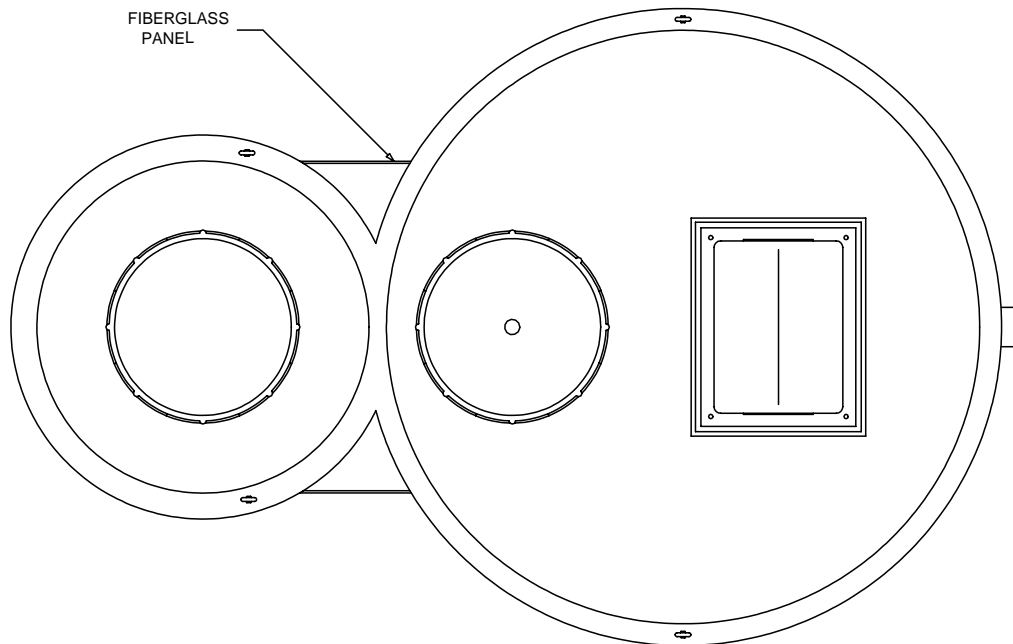

# Aqua Safe AS500 CU and AS600CU TT

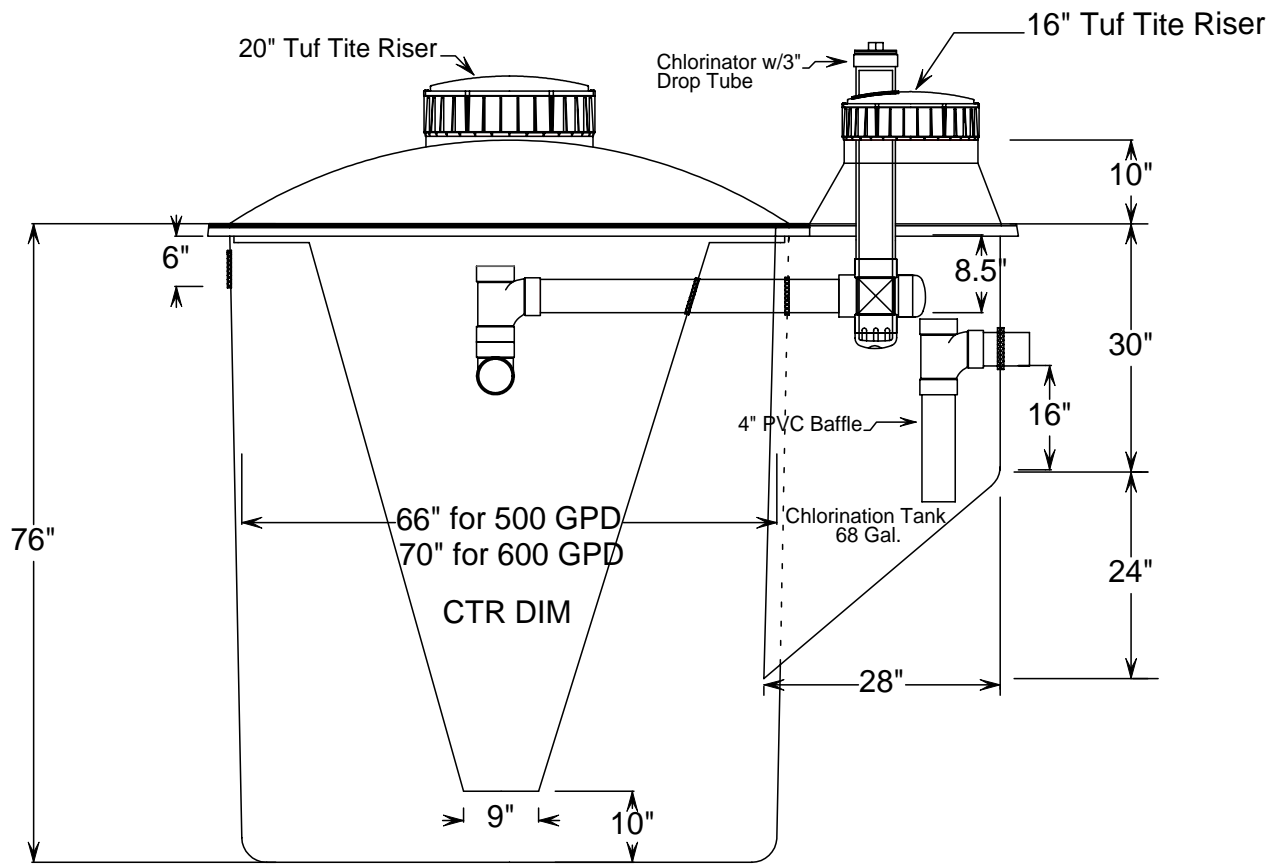
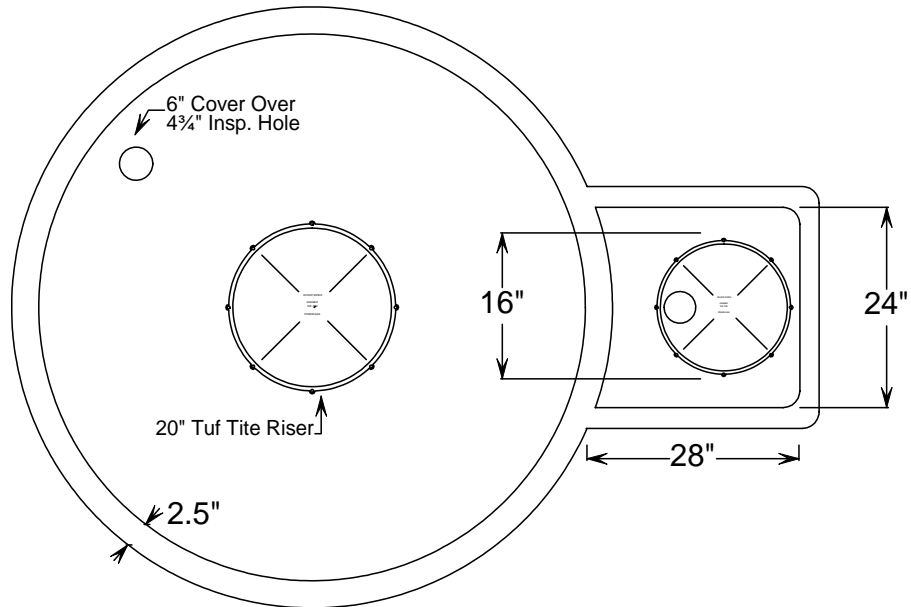

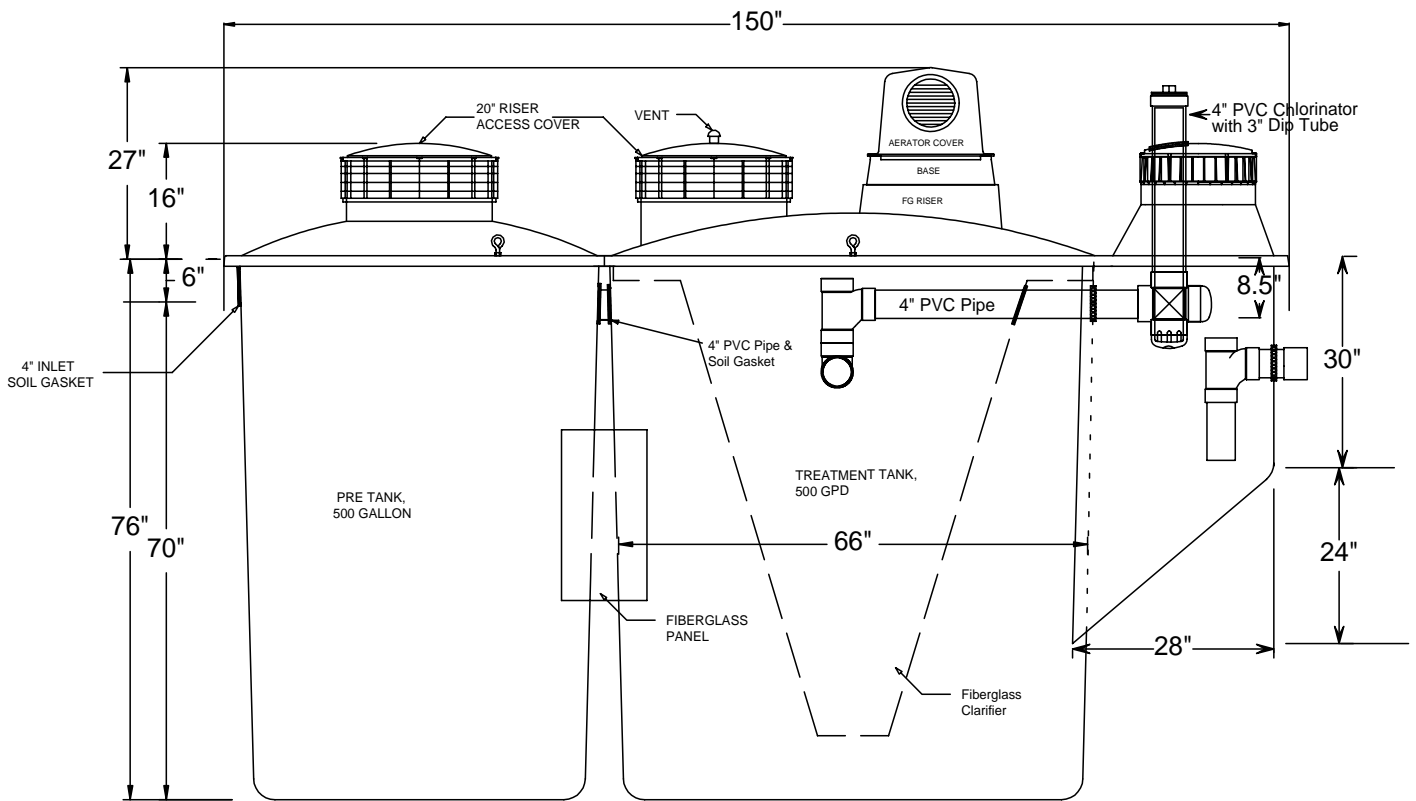
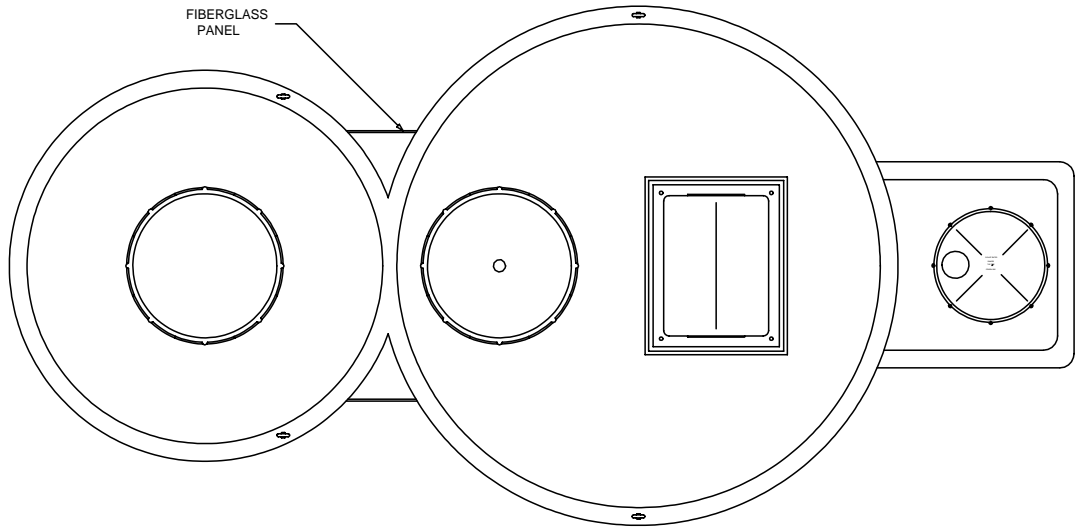

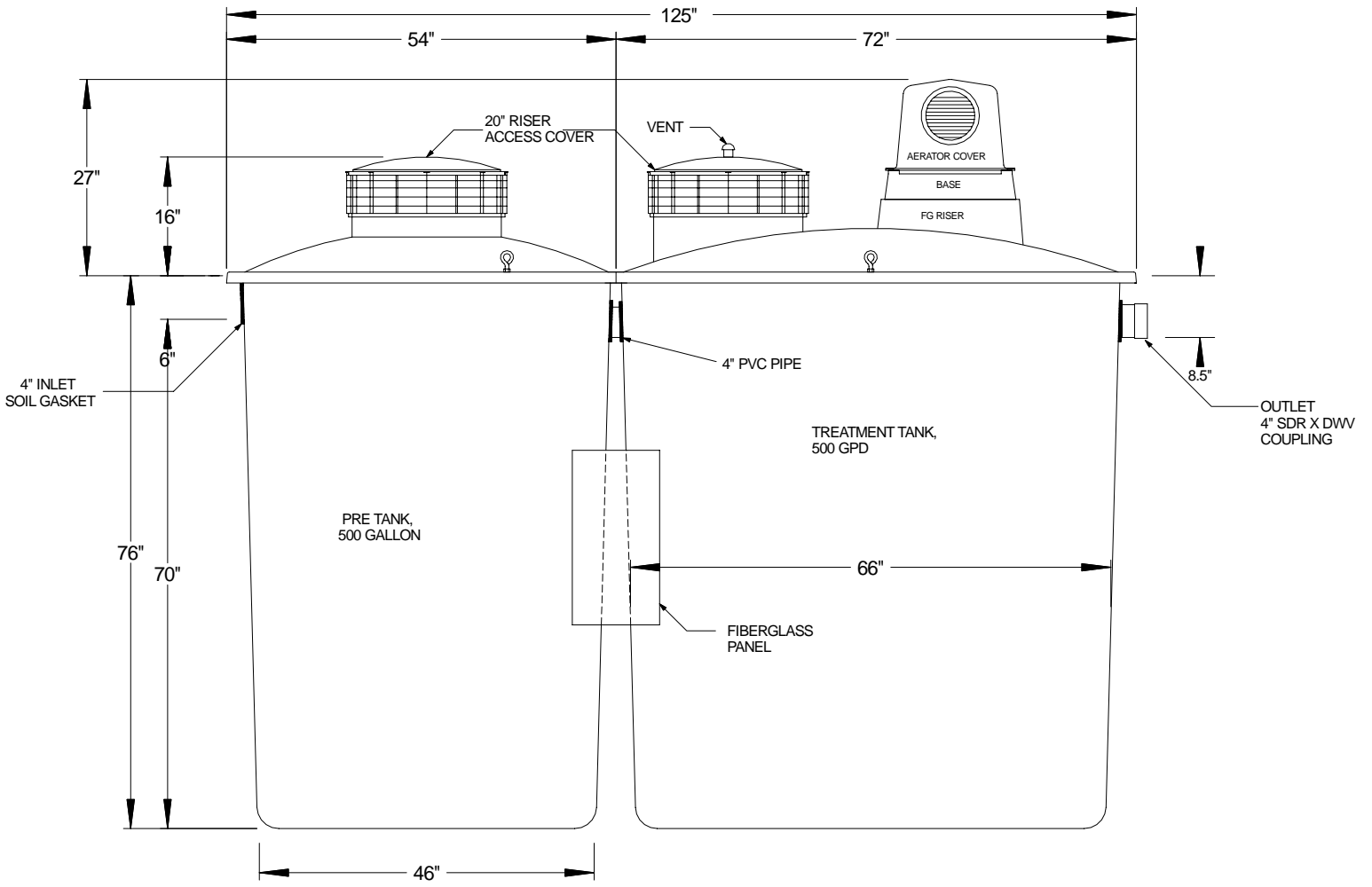
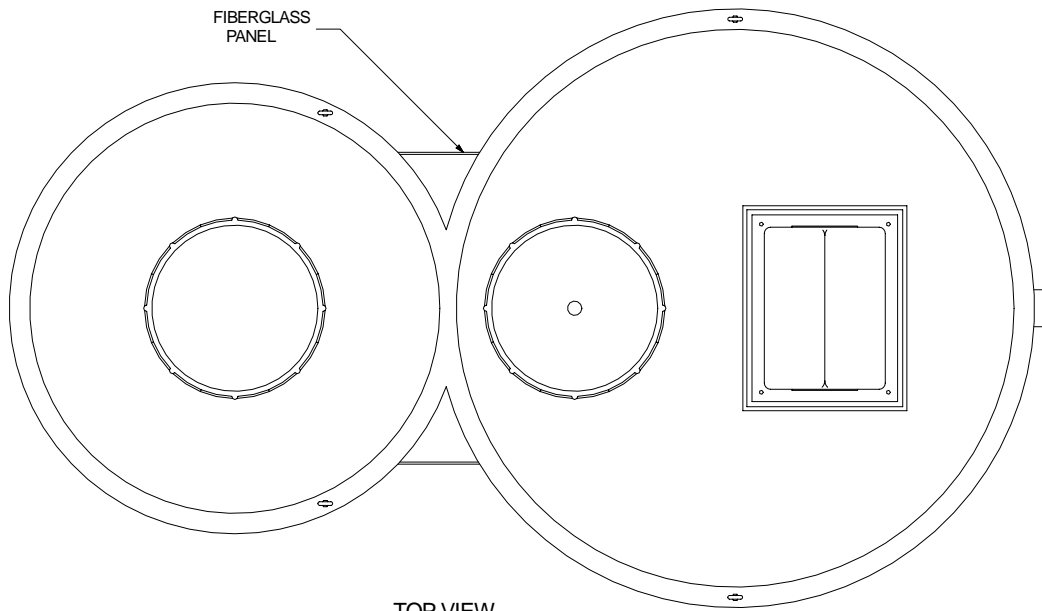

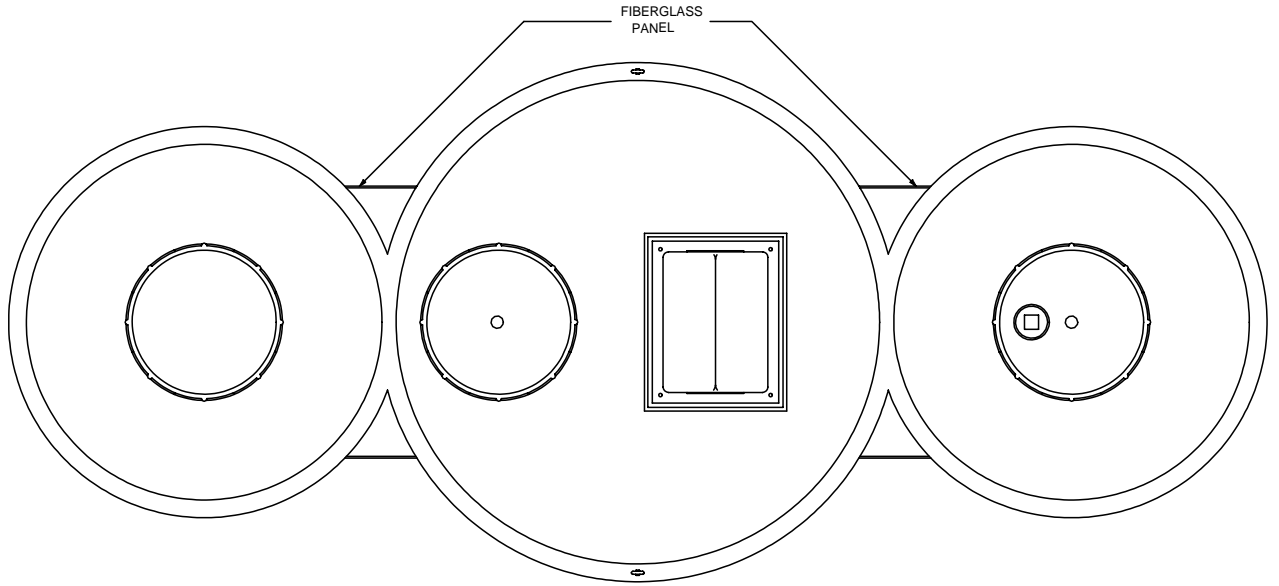

TOP VIEW

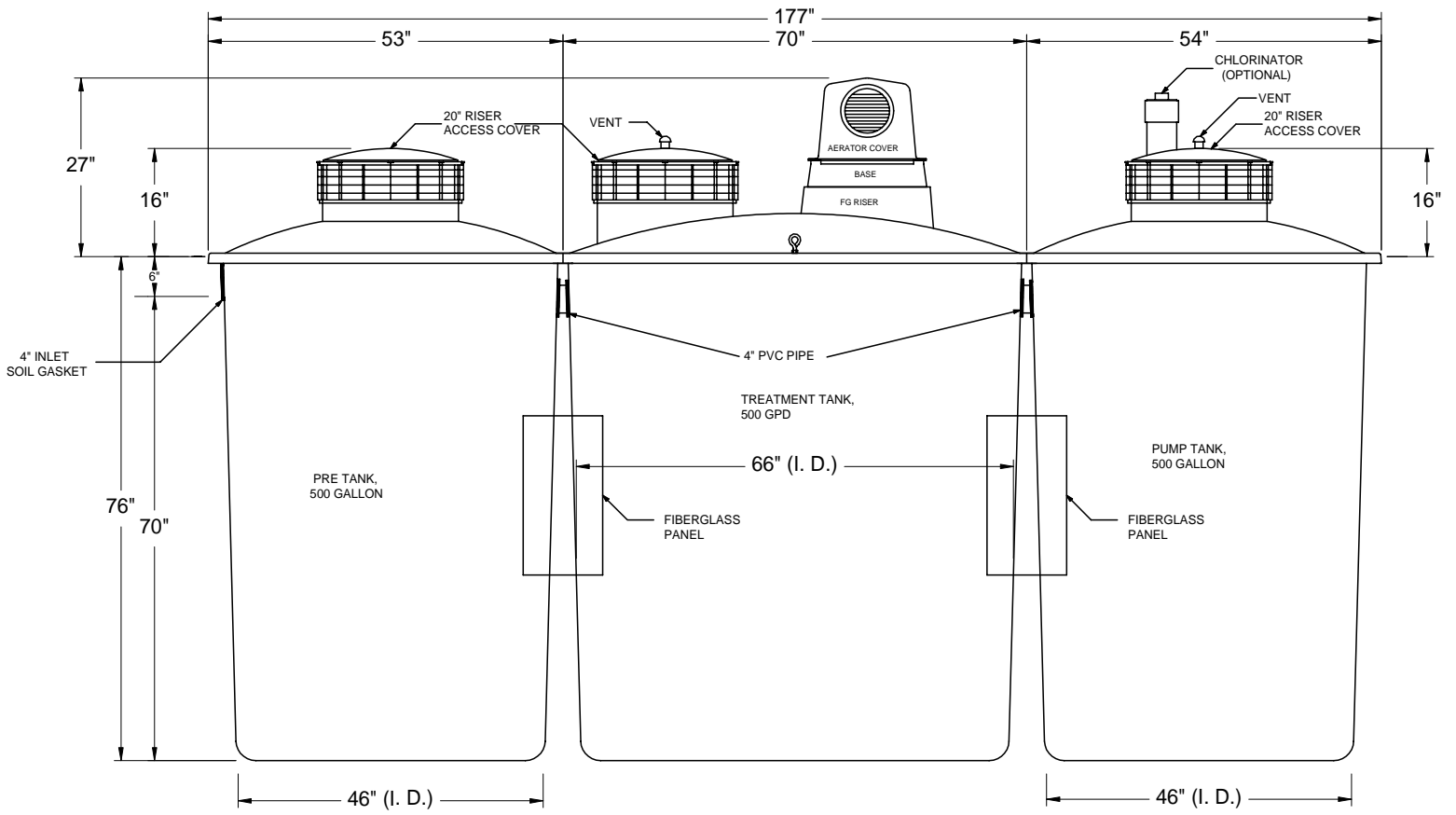

SIDE VIEW

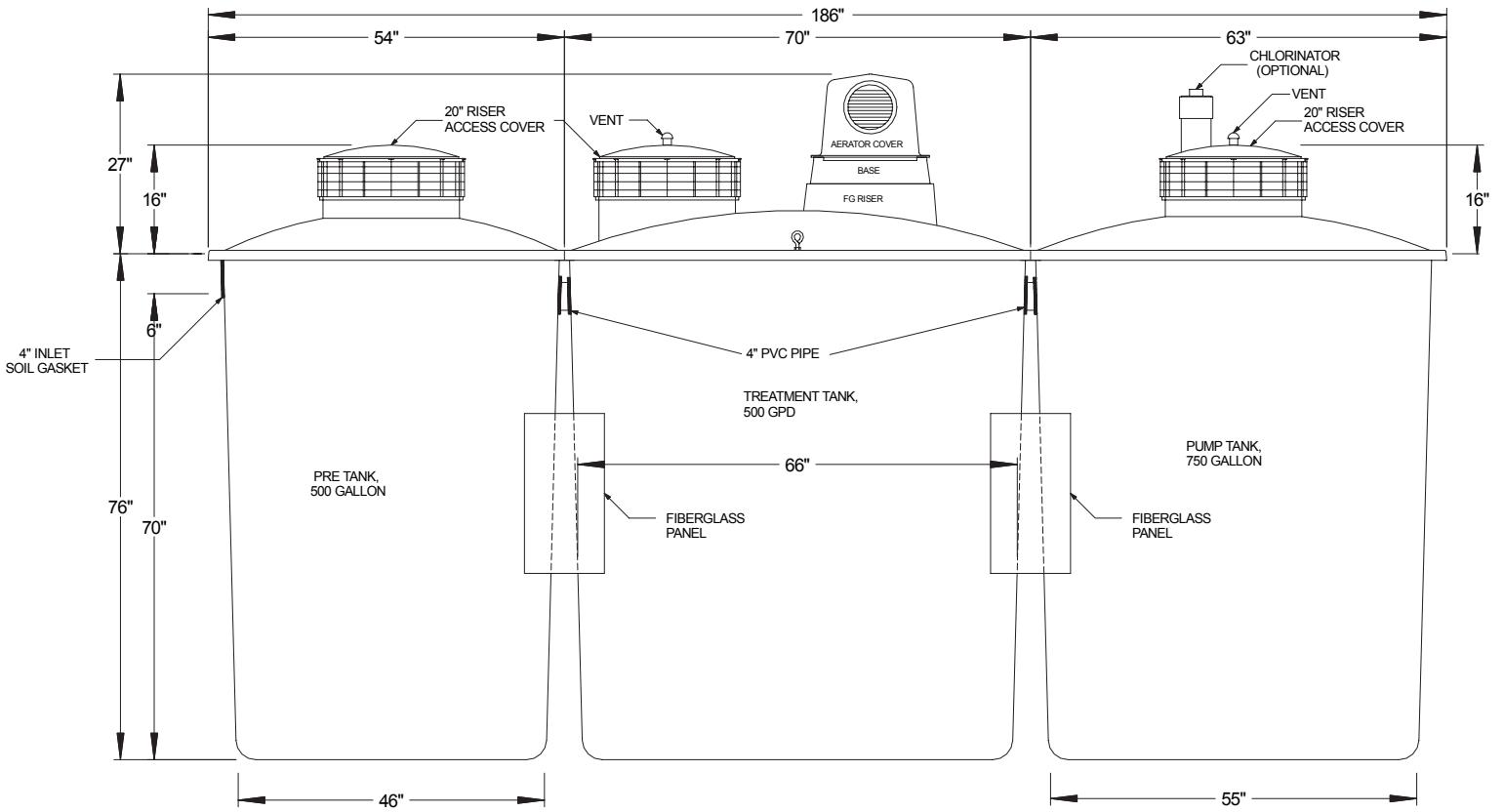
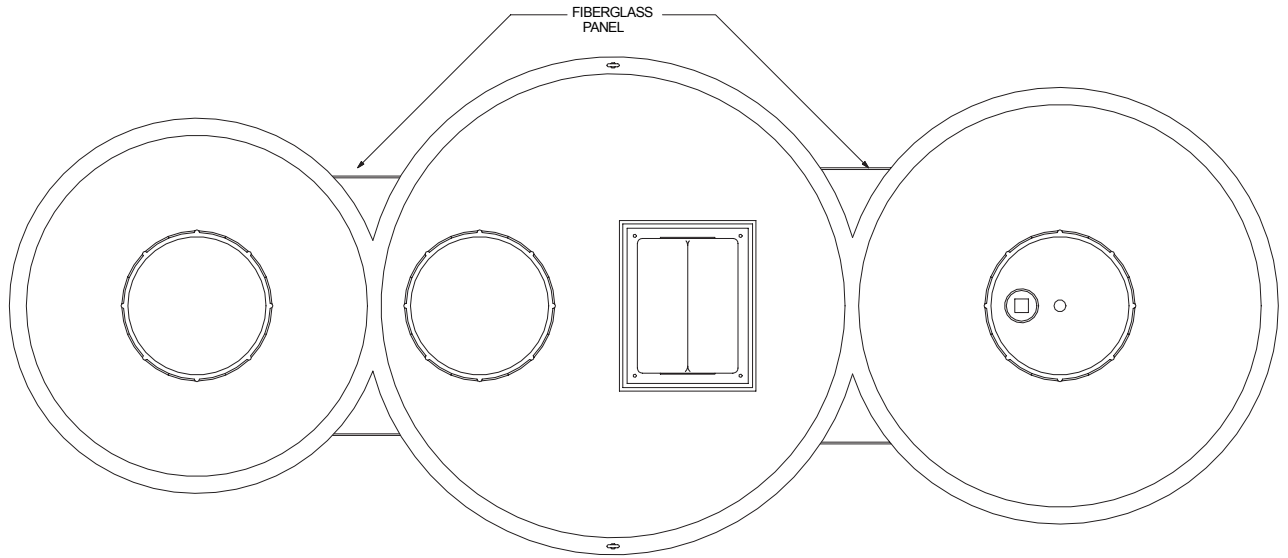

# AS500+5 Pre Concrete Tank with Lid

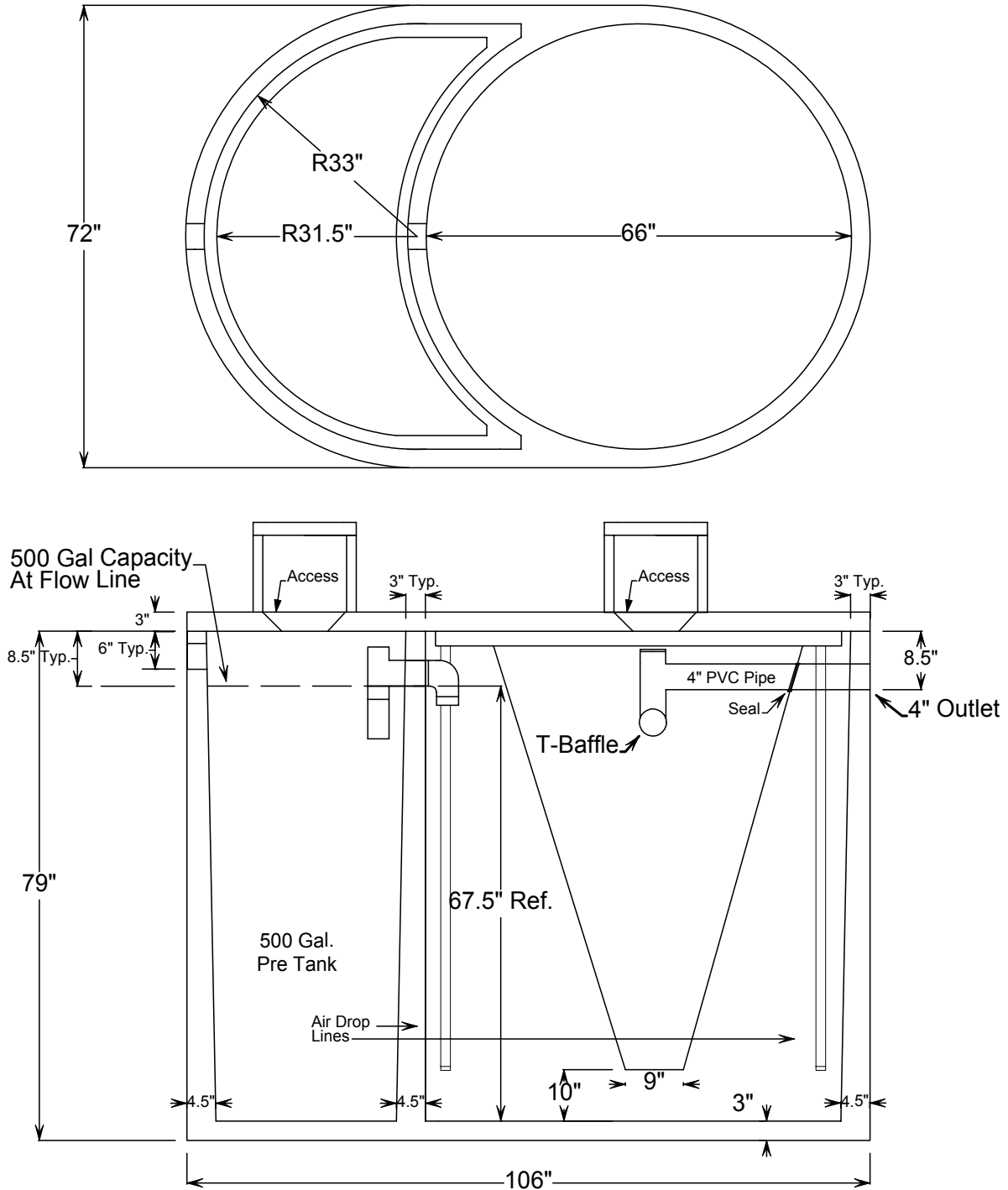

# AS500 4+75 Concrete Tank With Lid

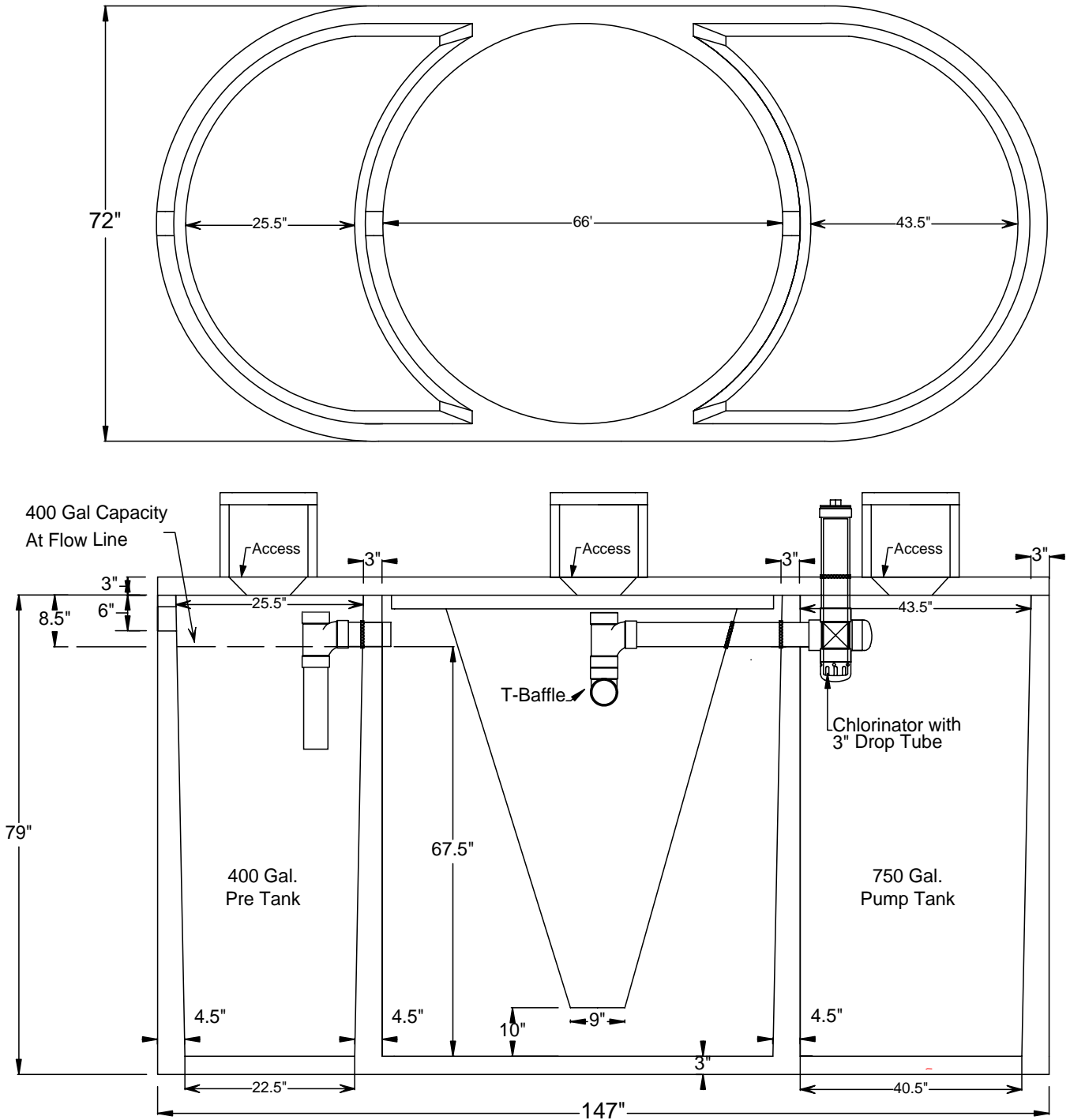

Ecological Tanks, Inc.

Patented

4/2002

FIGURE 12

# ECOLOGICAL TANKS, INC.

2247 Hwy. 151 North  
Downsville, LA 71234  
Phone: 318-644-0397  
Fax: 318-644-7257

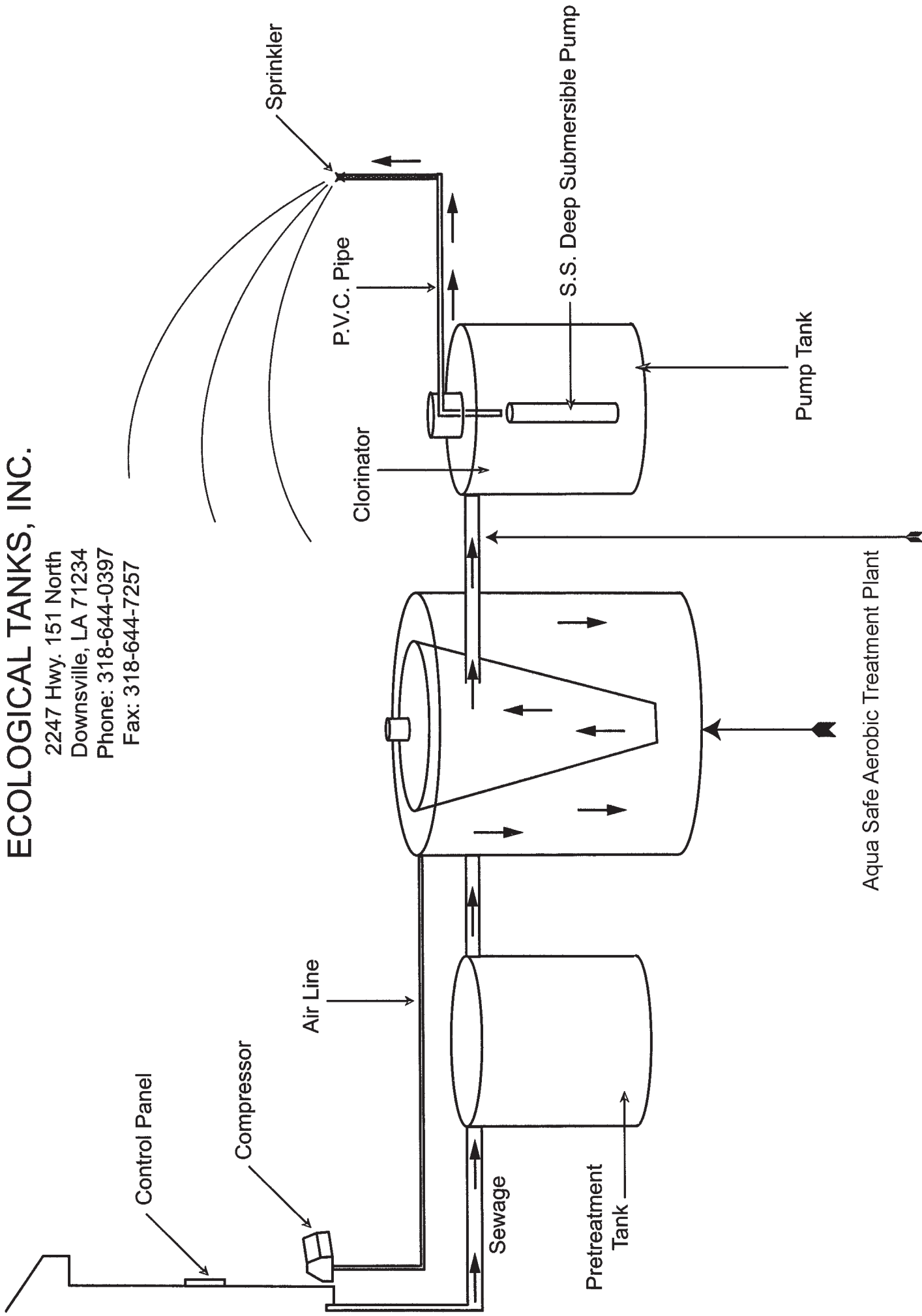

Aqua Safe Aerobic Treatment Plant

At this point the waste water is 97% pure and odorless

# AQUA SAFE TREATMENT PLANTS AIR LINE DIFFUSION

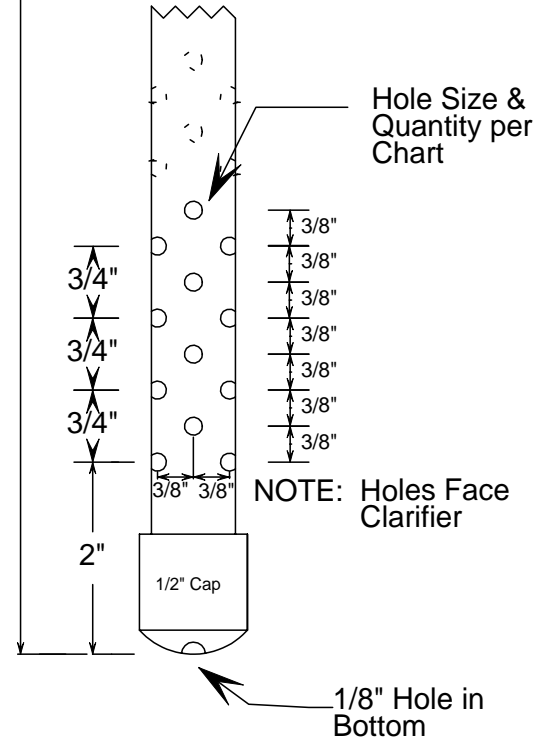
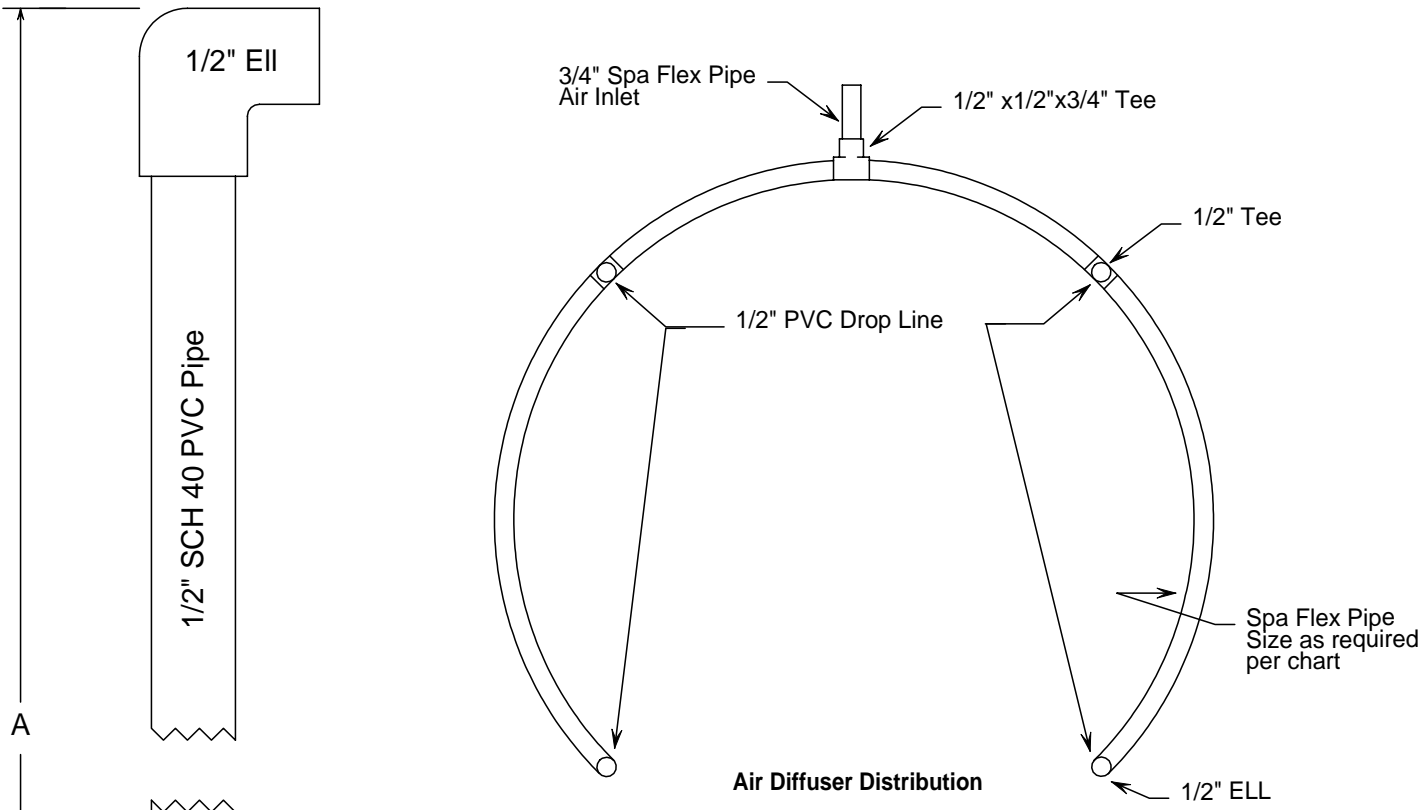

Drop Line Design Chart

UNIT	DROP LINE (A) SIZE & LENGTH	NO. HOLES		PATTERN	HOLE SIZE	SPA DISTRIBUTION
		SIDE	BOTTOM			
500	1/2"-64"	12	1	3/4x3/8 Stag	3/32"	1/2" Loop
600	1/2"-64"	15	1	3/4x3/8 Stag	3/32"	1/2" Loop
750	1/2"-64"	12	1	3/4x3/8 Stag	1/8"	1/2" Loop
1000	1/2"-86"	15	1	3/4x3/8 Stag	1/8"	3/4" Loop
1500	1/2"-86"	18	1	3/4x3/8 Stag	1/8"	3/4" Loop

### III. AQUA SAFE® RECOMMENDED PLANT INSTALLATION INSTRUCTIONS

1. Inspect entire treatment plant and component parts.
2. Select location of plant site which is accessible to the home sewer discharge line, at least ten (10) feet from the home foundation, in an area that will not receive vehicular traffic. Prepare an excavation site by digging a hole at least one (1) foot larger than the treatment plant and a depth that will allow for sufficient coverage leaving approximately three (3) inches of the inspection port to extend above normal ground level. The depth of the plant will be controlled by the depth of the building sewer outlet line plus the amount of proper fall required from the building sewer outlet to the inlet invert of the plant. The prepared excavation should have a solid, level bottom that will eliminate plant settling. Additionally, the bottom of the excavated hole should be free of rocks or sharp objects. **Aqua Safe®** plants should be installed on a bed of sand on undisturbed soil to provide a solid flat base.
3. Utilizing lifting lugs provided, carefully place the plant in the excavation. The inlet line should slope down toward the plant and the outlet line should slope down away from the plant. The plant should be level to within one (1) inch, edge to edge. **Aqua Safe®** wastewater treatment plants should only be connected to properly trapped and vented plumbing systems in compliance with state and local plumbing codes.
4. Position the inlet and outlet lines and make the necessary connections. Clean-outs should be installed at building sewer tie-in, any changes in direction of flow and at maximum intervals of seventy (70) feet when using four (4) inch piping. The inlet line should be inserted and glued into the inlet elbow and the discharge line should be inserted and glued into the outlet coupling. Open the inspection port on top of the plant and make sure the discharge tee assembly is level and centered in the clarifier prior to connecting discharge piping. Fill the tank with water to the point of flowing discharge before backfilling. Backfill evenly around the plant, up to the bottom of the inlet and outlet piping, taking care not to damage the tank or dislodge the piping. Backfill material must be void of rocks, gravel, heavy clay or any type of material which might damage the tank.
5. The aerator compressor must be installed in a well ventilated, relatively clean and dry location. Install the aerator compressor on the treatment plant's tank top or at a remote location no more than one hundred (100) feet from the treatment plant. The aerator compressor is supplied complete with all discharge fittings. Install 3/4" Sch. 40 PVC piping (supplied by others) between the aerator and treatment plant. Be careful not to allow any debris, dirt or mud in the airline during installation. A minimum of twelve (12) inches ground cover is recommended over the 3/4" Sch. 40 PVC air piping.
6. The electrical controls for the aerator compressor, visual and audible alarms for compressor failure and high water conditions, dose/spray pump and/or timer are contained in a weather proof enclosure. (See Figures 15-34). It may be installed in any above ground area where the warning light is visible to the owner during the course of a normal day activities. It is recommended that the control box be at least six (6) inches above ground level and in view of the aerator compressor housing. All electrical wiring must comply with applicable standards and shall conform to the requirements of the most current revision of the National Electrical Code. All electrical components not supplied must comply with U.L. standards. We recommend that all electrical connections be made by a licensed electrician.
7. Install electrical wiring (provided by others) to interconnect the aerator compressor and alarms to

the electrical control panel. (See Figures 16-33). A minimum of twelve (12) inches of ground cover is recommended over underground electrical conduit and wiring.

8. If required, install the application pump in the pump tank. (See the **Aqua Safe®** effluent pump manual). Most aerobic system designs that include as a method of effluent disposal surface spray, subsurface drip, or low pressure dosing should include the proper sized pump for the job. If not, once the pumping conditions are determined, selection of the right pump will be determined by two factors, pump capacity and total head needed. You must match the pump as closely to your conditions as possible to get maximum pump efficiency and dependable operation. Install and set the float switches to the appropriate level to comply with design and state requirements. (See Figures 20 & 21).

9. Run approved conduit and wiring to the pump tank from the control panel and have a qualified electrician make wiring connections. (See figures 26-33 and **Aqua Safe®** pump manual). All conduit running from the pump tank to control panel must be sealed with conduit sealant to prevent moisture or gases from entering the panel.

10. The aerator compressors used on **Aqua Safe®** wastewater treatment plants run continuously. They provide relatively quiet, energy efficient operation. Once properly connected, the electrical control box is to be closed. Operate the aerator compressor by placing the on/off electrical circuit (provided by others) in the ON position.

11. Turn on aerator compressor and check all air piping and fittings for leaks. This can be accomplished by preparing a saturated solution of soap and water and applying to entire run of pipe and fittings. If a leak is detected, effect repairs.

12. Carefully backfill all underground lines and the rest of the plant's excavation in a manner which will not cause damage to the completed installation.

13. The **Aqua Safe®** plant is ready to receive incoming sewage.

#### **IV. AQUA SAFE PLANT START UP**

Initially the **Aqua Safe®** wastewater treatment plant is filled with clean water, usually from an owner's water supply. As stated in the installation instructions, once all proper connections have been completed and it is filled with water and the aerator compressor turned on, the system is now in operation. For the treatment plant to be biologically stable, it will take from four (4) to twelve (12) weeks after first using the plant to develop a population growth of microorganisms (bacteria). It is these bacteria which make the treatment system operate.

#### **V. OWNER MAINTENANCE CARE AND OPERATION INSTRUCTIONS**

**Aqua Safe®** home wastewater treatment plants have been designed and built by **Ecological Tanks, Inc.** to provide long term, reliable and cost efficient service. Our treatment plants will operate with a minimum amount of attention.

If service is required, reference the system's DATA PLATES located on the **Aqua Safe®** control panel or aerator compressor for the plant's model number, the name, address and phone number of the local service person that can provide service. The following procedures should be performed on a routine basis to insure proper plant operation:

**DAILY:** Check warning light and audible alarm located on the plant's control panel for air supply malfunction or in system high water indication. If an alarm on condition is observed, it is an indication of malfunction. First check the electrical circuit providing power to the system to insure the circuit is closed. Check the aerator compressor to be sure it is operating. Check for over heating, excessive vibrations and unusual noises. If aerator compressor failure is observed, call your service provider for service. After a power outage, an alarm condition may exist. Should an alarm remain on for more than thirty (30) minutes after power is restored, you should call your local service provider to report the alarm.

**WEEKLY:** Check the treatment plant for offensive odor. If present call for service.

**PERIODICALLY:** Check and clean the air filter on aerator compressor. Rinse with warm water to clean if necessary. Make sure filter is dry and re-install on aerator compressor.

**RECOMMENDED:** Frequency of solids removal is no more often than every two (2) to five (5) years. Determination of the need for pumping can be made only by a trained service person by testing the tank contents and/or effluent. The **Aqua Safe®** wastewater treatment plant should be pumped when the settled solids are approximately sixty (60) percent of the total volume. **WARNING** - Hydraulic displacement and tank flotation may occur whenever tanks are pumped. Upon completion of pumping, tank **must** be refilled with water. Additionally, care should be taken not to damage internal component parts. A certified **Aqua Safe®** service technician should oversee tank pumping.

## **VI. OWNER'S RESPONSIBILITY**

It is the *owner's responsibility* to operate the **Aqua Safe®** wastewater treatment plant to the best of their ability. To keep maintenance to a minimum and insure high effluent quality, the following items should not be permitted to enter the treatment plant:

1. Strong disinfectants or bleaches, other than small amounts used in day to day house cleaning and laundries. Recommended detergents are low-sudsing, low phosphates and biodegradable. Recommended cleaning products are non-chlorine, non-toxin, non-corrosive and biodegradable. Anti-bacteria soaps should be avoided.
2. Backwash discharge from any type of water softeners.
3. Citrus products, coffee grounds, chemical wastes, paint or paint thinners, oils or grease (such as used cooking grease), pet shampoo, pet dip disinfectant, pesticides, herbicides, automotive fluids or any other toxins.
4. Disposable diapers, tampons, sanitary napkins, large quantities of paper products, tobacco products, or similar items. Home brewery waste, strong medicines and antibiotics.
5. Waste material from a garbage disposal is not recommended without the use of a trash trap or pretreatment tank preceding the **Aqua Safe®** plant. Food waste represents additional loading the aerobic treatment unit would have to digest, increasing pump out intervals.
6. The **Aqua Safe®** wastewater treatment plant is designed for the treatment of **domestic wastewater** and nothing else should go into it. During extended periods of intermittent or non-use, such as vacation time, the aerobic bacteria inside the plant will decrease due to no food in the form of incoming wastewater. The treatment plant will become biologically stable again soon after the resumption of normal loading. The aerator compressor should be left on during periods of vacation

time. During extended periods of absolute non-use (3 months or longer) the aerator compressor should be removed, cleaned and stored with the compressor's inlet and outlet sealed. Additionally, the air line piping should also be capped to prevent debris from entering the air distribution system.

The **Aqua Safe®** plant will not perform to its fullest capabilities if subject to hydraulic overloading. This condition exists whenever excessive water, above the plants designed treatment capacity, is allowed into the plant. Leaking plumbing fixtures or excessive water use may cause this condition. Hydraulic overload may also occur on wash days, when multiple loads of laundry are washed in succession.

**Ecological Tanks, Inc.** is not responsible for the infield operation of our plants. The proper operation of this wastewater treatment plant depends upon proper organic and hydraulic loading of the plant. We cannot control the loading of substances in our plants that may upset its biological balance. We can only provide a complete owner's manual which outlines materials that should be kept out of the treatment plant. User operation instructions must be followed or warranties are subject to invalidation.

**WARNING!** Ants and rodents are destructive to the mechanical and electrical equipment on wastewater treatment plants. Care should be taken to prevent infestation of ants near the plant. Damage or destruction of mechanical or electrical equipment by ants or rodents is not covered under manufacturer's warranty.

Any and all safety requirements such as the electrical wiring, blower operation or plant discharge concerning the owner, their families, friends, or guests is the sole liability of the owner (see warranty and service policy).

The electrical control panel contains a schematic for the system. However, the electrical control panel is sealed and contains no user serviceable parts. Test and alarm silence switches are located on the outside of control panel.

**WARNING!** Service to the electrical control panel by a non-qualified person may result in a electrical shock hazard resulting in serious injury or death. If service is required contact your local authorized installer representative or maintenance provider.

Many states already require the use of a chlorination unit behind all mechanical treatment plants for total effluent disinfection prior to final discharge. **Ecological Tanks, Inc.** recommends the use of a disinfection device behind its mechanical plants for total effluent disinfection prior to final discharge.

## **VII. INSTALLER/MAINTENANCE PROVIDER OPERATION, REPAIR AND TROUBLESHOOTING**

Previous sections in this manual have covered the **Ecological Tanks, Inc., Aqua Safe®** system's functions, specifications, design, proper installation procedure, start up, owner care and operation instructions. If at this point you are not totally familiar with the material already covered, you should read it again.

Please pay particular attention to the preceding section titled Owner's Responsibility. This section covers information critical to the plants proper loading and function. You will find that this same information is listed in the **Ecological Tanks, Inc., Aqua Safe®** Owner's Manual. Your assurance of the owner's receipt of their manual and the explanation of it's contents is most critical to the

plant's proper operation.

You will find, in the following sections of this manual, the Initial Service Policy. It covers information required of you as a maintenance provider in order for you to provide service in compliance with NSF/ANSI Standard 40. Additionally, most states have added to the requirements of this policy. You must know and adhere to all other regulatory agency requirements concerning mechanical plant service/maintenance standards. **Ecological Tanks, Inc., Aqua Safe®** wastewater treatment plants should be inspected every six months for proper operation. Two years of maintenance is provided as a part of the systems certification requirements. Ongoing maintenance is usually part of a service agreement maintained between an owner and maintenance provider. Inspections should include any necessary adjustment of electrical controls and servicing of the component parts and should include a visual check of hoses, wires, leads, contacts, cleaning of filters, removal of organic particles, and testing of alarms to ensure proper function. An effluent quality inspection consists of a visual check for color, turbidity, scum overflow, and an examination for odors. A mixed liquor inspection may be necessary if the plant is not performing properly or if offensive odors are present. If any improper operation is observed which cannot be corrected at that time, the user shall be notified in writing immediately. This notification shall advise the owner of the problem, if it is covered by the warranty, if not, the cost related to correcting the problem and estimated date for correction of said problem.

#### **VII-1. EXAMPLE OF A ROUTINE MAINTENANCE SERVICE CALL**

First check the system's control panel for any alarm or failure indication. Check the panel to insure proper incoming power by testing the incoming power supply. If you know power is incoming into the control panel, check the circuit feeding the control panel. Next, check the aerator simply to insure that it is running and then go directly to the treatment plant for an effluent quality inspection as outlined in the service policy section. At this point pay particular attention to odors you notice at the plant (or pump tank if applicable). You may notice an earthy smell which is nothing more than carbon dioxide gas emitted by the aerobic bacteria in the plant. There may be a sweet smell or no smell at all and that's good. Should you experience an obnoxious odor, something is wrong. Access the aeration mixing compartment, if necessary, to examine the mixed liquid and air diffusion system.

Return to the control panel, check for proper functions as outlined in this manual (See figures 15-24), note the troubleshooting and repair guidelines covered in the referenced figures. Before servicing the control panel and alarm system, disconnect power to the control panel.

Clean or replace the aerator compressor air filter at this time. If you experienced an offensive odor when at the plant and heard little or no bubbling, finding a clogged or extremely dirty air filter may be the problem. Turn on the aerator at this time and check for any air leak between the aerator and the 3/4" Sch. 40 PVC piping. If a leak is detected, effect repair. If a leak is not detected, the following steps should be taken.

Remove the aerator from the rubber hose connection and install a low pressure gauge between the PVC piping and aerator. Turn on the aerator and note the pressure. If the line pressure is below 1.5 P.S.I. then there is a leak between the aerator and the air distribution system in the treatment plant or the aerator's diaphragm is ruptured. (See the aerator compressor repair section) Determine the cause and effect repairs at this time. If a pressure above 3.5 P.S.I. is noted, the air system piping or diffuser assembly is blocked. You can clear the air distribution system's blockage by charging the air distribution piping with compressed air (no more than 80 P.S.I.) Re-check the line pressure after any maintenance procedure to the plant's air distribution piping to insure the correct pressure range.

The normal line pressure should be between 1.83 PSI and 2.85 PSI.

The **Aqua Safe**® aerobic treatment plant was designed and tested with a specific aerator compressor for each of its plant models (See Figure 35). Use only the specified aerator for each plant model provided by **Ecological Tanks, Inc.** in accordance with NSF Standard 40.

If this particular system uses a gravity flow overland discharge, check to insure the discharge pipe or manifold is open. Should the system employ spray irrigation or some other method of pumped effluent disposal, you should check that method at this time.

While at the chlorination or pump tank, if applicable, note the condition of the chlorination or other type of disinfection device. Make sure that the disinfection device is designed to insure effluent contact with the disinfection agent during periods of final effluent flow into the pump tank. Note the chlorine supply and check to insure that chlorine tablets are not caking inside the chlorinator resulting in no tablet to effluent contact. Effect necessary repairs if needed.

Continue at the pump tank by checking the condition of the application pump and it's electrical connections. Note the positions of the pump on, off, override and high water float switches. Make sure they are properly positioned, operable and secured. Note the condition of the application pump's inlet screen. Clean or replace as necessary. Check to insure the pump is properly seated in the pump tank and note the condition of the pump's drop pipe as it extends from the pump discharge opening to the exit point out of the pump tank. Refer to Troubleshooting Guide found on the back page of the **Aqua Safe**® effluent pump manual if application pump problems warrant corrective action or repair.

Some counties require the use of a spin or disc filter in line between the pump tank and spray application area. If subsurface drip application is used, you should always have a filter assembly in line between the pump tank and drip field. Counties that require the use of in-line spin or disc filters, as well as drip tubing manufactures alike, prescribe the use of the filter size and micron rating (normally 100 microns). Only approved filters should be used. If spin or disc filters are used they should be removed and cleaned or replaced and re-installed at this time.

Continue by next checking the condition of the final effluent distribution piping system to include the surface spray or subsurface drip application area. Be sure that the distribution piping system and any repairs to the system conform to the applicable rules governing the construction of that system. Note any ponding or run off from the disposal area; determine the cause if either of these conditions exist. Probable cause would be either hydraulic overload of system or improperly sized disposal area. If water is ponding in the disposal area, it may flow back into the pump tank if the in-line check valve between the pump tank and disposal area is not completely closing after each pump cycle. Note any non-compliance conditions that may exist in the effluent disposal area and arrange for corrective measures.

Activate the application pump and check the spray pattern and condition of the spray heads in the surface application area. Strainer screens if used in the spray heads may require cleaning. Any irregular spray pattern or damaged spray head must be noted on the reporting record and repaired. Also note the condition of the vegetation growth in the surface application area. Tall grass, weeds or bushes should be cut or trimmed. Notify the person responsible for performing that task and insure that it is done.

If a subsurface drip application field is used, the system should be flushed at each regular service visit. Systems must be equipped to flush the contents of the lines back to the pretreatment tank when

intermittent flushing is used. If continuous flushing is used during the pumping cycle, the contents of the lines must be returned to the pump tank. Check the atmospheric vents in the drip field to insure that they will open to vent and are readily accessible for inspection or service.

Recommended procedures for taking effluent samples are outlined in Section VIII of this manual, titled Effluent Sampling Requirements.

Be sure to follow the steps outlined in the Initial Service Policy, number 3, should you observe any improper condition affecting the plants proper operation which cannot be readily repaired.

## **VII-2 AERATOR COMPRESSOR REPAIR**

Linear aerator compressors (See Figure 36-38) are used on all models of the **Aqua Safe®** wastewater treatment plants. They provide quite energy efficient operation. Additionally, rotary vane compressors (See Figures 39-42) are provided upon request, in-lieu of linear aerator compressors. All aerator compressors on all models of the **Aqua Safe®** aerobic wastewater treatment plants run continuously.

Periodical aerator compressor maintenance will help you to operate the aerator in the optimum condition and insure longer aerator life. Air filters should be cleaned every four months and replaced as necessary. **Ecological Tanks, Inc.** recommends that the air filters be replaced once a year. The plant's air distribution piping pressure should be measured at least once per year. Aerator compressors should be operated at the recommended output pressure range which is between 1.5 and 3.5 P.S.I. Aerator life is shortened if operations outside of the specified pressure ranges occur.

**Ecological Tanks, Inc.** recommends the diaphragm blocks on linear aerator compressors be replaced every three years. We also recommend that the vanes be replaced every four years on rotary vane aerator compressors. Referring to figures 36-42, note the following text for diaphragm block and vane replacement procedures:

### LINEAR COMPRESSOR HEAD AND DIAPHRAGM REPLACEMENT

1. Remove linear blower from electrical power and move to a well lit spot.
2. Remove the top plastic cover and discard the filter element.
3. Turn the blower over and remove (4) screws using either a #2 Phillips screwdriver or a 10 mm socket.
4. Remove the top housing and internal filter.
5. On Secoh, Thomas, and Gast HP series, remove the drive cover by taking out (4) Phillips screws.
6. Carefully, inspect the shuttle assembly and electric coils. Any damage to these components will require replacing the linear blower.
7. Using a pair of pliers, slide the hose clamp down the discharge hose and remove the hose from the head assembly.
8. Remove the head assembly by taking out (4) Phillips screws and separating the head from the

diaphragm casing by prying the two pieces apart at the notch in the head.

9. Remove the diaphragm lock nut and washer. Slide the diaphragm block off the shuttle stud.  
NOTE: On the Gast units only, the diaphragm ring will also be removed during this operation.

10. Install the new diaphragm and casing by sliding the diaphragm over the shuttle stud and centering the diaphragm casing in the housing. Install the washer. Place (1) small drop of Loctite thread lock on the end of the stud and install the nut. Tighten to 14 in. lbs.

11. Install a new head assembly by locating the head over the diaphragm casing and tightening the (4) Phillips screws.

12. Slide the discharge hose back on the head and replace the clamp.

13. Follow procedure #7 thru 12 for the opposite side.

14. Install the internal filter and replace the blower cover.

15. Install the (4) Phillips screws, replace the filter element, and replace the filter cover.

16. Return unit to service.

### ROTARY COMPRESSOR VANE REPLACEMENT

1. Unplug compressor, disconnect piping and move to a suitable work area.

2. Remove (5) 7/16" hex bolts and remove front cover and gasket (if present).

3. Remove vanes while paying particular attention to the proper orientation of vanes in the rotor.

4. Using low pressure compressed air, blow out any dust or carbon particles from rotor and cylinder.  
(Always use safety glasses when performing this procedure).

5. Inspect the rotor, cylinder, and front cover for any signs of metal contact or cracks.

6. Rotate the rotor by hand to be sure the motor and bearings are free.

7. Install a new set of (4) vanes into the rotor slots.

8. With the motor resting on its base, rotate the rotor by hand to insure the vanes move freely.

9. Install the front cover and torque the (5) hex bolts to 10 ft.-lbs.

10. Replace the felt washers on the inlet filter.

11. Prior to installing compressor back on system, plug the unit in and let it run for a couple of minutes. Unit should have a constant hum and should not exhibit any excess vibration.

12. Unplug the unit and listen for the coast down of the compressor. The compressor should coast down to a dead stop. If the unit stops immediately, go back to step #2 and check for any metal to metal rubbing.

13. Install unit back on plant.

### VII-3. METHODS FOR EVALUATION OF EFFLUENT AND MIXED LIQUOR

<b>Problem</b>	<b>Possible Cause</b>	<b>Corrective Action</b>
Offensive odor from plant and effluent.	Aerator or air piping defective, leaking or or clogged	Check aerator, air piping and alarm system.
Murky to gray mixed liquor with semi-clear effluent having a sour odor.	Plant starving due to infrequent loading, hydraulic overloading, or oversized pretreatment tanks resulting in totally anaerobic, or low BOD influent.	Confer with homeowner regarding loading. Remember it may take 4 to 12 weeks for a new plant to start.
Black colored mixed liquor & effluent having a totally septic odor void of dissolved oxygen, having a approximate pH between 6.5 & 8.	Plant receiving little or no aeration due to defect in aerator or air piping.	Check aerator, air piping & alarm system.
Black colored mixed liquor & black tinted effluent having an offensive odor & acidic pH	Plant loaded or dosed with influent that prohibits growth of aerobic bacteria	Confer with homeowner regarding loading. Adjust pH to between 6.5 & 8.5 dose system with approved bacterial additives to help restart micro-bacterial growth or pump tank for fresh start.
Brown mixed liquor with a viscous, brown foam having an obnoxious odor in the mixing zone with semi-clear effluent high in TSS	Developed population of filamentous microorganisms in aeration zone due to low food to microorganism ratios, the presence of toxins or improper pH level.	Confer with homeowner regarding proper plant loading. Adjust pH to 6.5 & 8.5. Dose plants mixing zone with approved bacterial additive.
<b>Problem</b>	<b>Possible Cause</b>	<b>Corrective Action</b>
Chocolate brown mixed liquor with clear effluent quality having only a slight earthy smell in mixing zone.	Plant working properly with effluent pH between 6.5 & 8.5 and D.O. level between 1 and 5.5 mg/L.	None required

## VIII. EFFLUENT SAMPLING REQUIREMENTS

When properly loaded, operated and maintained the **Aqua Safe®** wastewater treatment plant should provide an effluent quality consistent with the E.P.A. secondary treatment guideline parameters. The expected final discharge from the plant should provide an effluent quality of:

less than	25 mg/l.	CBOD5
less than	30 mg/l.	TSS
pH of	6 to 9	

Test results conducted by Baylor University's Department of Environmental Studies in accordance with NSF/ANSI Standard 40 requirements showed the **Aqua Safe®** wastewater treatment plant to have a 30 day effluent average of:

2.37	mg/l.	CBOD5
2.11	mg/l.	TSS

**Ecological Tanks, Inc.** recommends that ALL final effluent samples be taken in the effluent discharge line or the effluent pump discharge line at a sampling port designed for that purpose, but always after the chlorine contact tank. We recommend allowing the effluent to flow through the discharge pipe for a minimum of two (2) minutes before taking the sample.

### VIII-1. SAMPLING AND TESTING PROCEDURE FOR BOD5 OR TSS

1. Effluent grab samples to be analyzed for BOD5 or TSS should be done by a certified testing lab. The certified lab should provide you with information concerning proper sample collection to include volume, storage and labeling of sample. For a fee, most labs will provide the glass or plastic bottles to be used.

2. Always follow your testing lab's instructions concerning proper sample labeling, collection, and storage.

For the referenced sample collection in this section, the testing lab's minimum instructions should be:

A) Label each sample to include:

- \* Name and physical address of owner
- \* Time and date of collection
- \* Desired test
- \* Name of person collecting sample

B) Collect samples only in clean glass or polyethylene bottle or jar at a volume specified by the lab.

C) Store samples in a cooler to near freezing temperature as soon as samples are collected.

D) Deliver samples for analysis within six (6) hours of collection.

3. Activate the application pump and collect the sample from the sample port in the pump tank or from fresh flow in the effluent discharge line after the disinfection device.

## VIII-2. TESTING FOR SOLIDS REMOVAL

1. As previously noted in other sections of this manual a sample of mix liquor should be taken from the aerobic plant's aeration mixing compartment to determine the suspended solids content of the aeration compartment.
2. Using a clear glass or plastic graduated cylinder, let the sample settle for thirty (30) minutes. If the settled amount of suspended solids is greater than sixty percent (60%) after thirty (30) minutes, the aerobic tank should be pumped out.

## VIII-3. OTHER TESTING

1. To determine the composition of the aerobic plant's influent wastewater strength, collect a grab sample from the flow between the pre-treatment tank and aerobic treatment plant.
2. Samples should be taken from fresh flow directly out of the pre-tank's outlet baffle. Refer to information covered earlier in this section for proper handling of a sample from the job site to a certified testing lab.
3. Influent grab samples, at a minimum, should be analyzed for BOD5, TSS, COD, and pH. A pH test can be done on the job site by following the simple instructions with your pH test kit. However, BOD5, TSS, and COD tests should be conducted by a certified lab.
4. The need to determine the concentration of other influent contaminants may arise. Collect, handle and test the samples in the same manner as outlined in this section.
5. The typical composition of untreated residential wastewater for the suggested parameters is:

BOD5	180 to 200 mg/l
TSS	180 to 200 mg/l
COD	75 to 150 mg/l
pH	6 to 9

## IX. ORDERING OF SYSTEMS, PARTS, AND MANUALS

**Ecological Tanks, Inc., Aqua Safe®** maintains ample supplies of parts to meet the needs of new sales, replacement parts, warranty parts, and manuals. Please feel free to call us or your local distributor so we can help meet these needs.

## SOURCES FOR OBTAINING REPLACEMENT PARTS OR COMPONENTS

Replacement parts or components may be obtained from your local installer/distributor or from:

### **Ecological Tanks, Inc.**

2247 Hwy 151 N.  
Downsville, LA 71234  
Office: 318-644-0397  
Fax: 318-644-7257

## PARTS LIST

Refer to system, aerobic control and aerator compressor schematics.

## DATA PLATE / SERVICE LABELS INFORMATION

<b>AQUA SAFE</b> ®	
	Ecological Tanks, Inc. 2247 Hwy 151 N. Downsville, LA 71234 318-644-0397
<b>Model # ASXXXX-XXX</b> <b>Class 1 Size XXXX GPD</b>	
<b>For service call your local service provider</b>	

*The above weatherproof vinyl label is permanently affixed to the front of the electrical control panel.*

<b>AQUA SAFE</b> ®	
	Ecological Tanks, Inc. 2247 Hwy 151 N. Downsville, LA 71234 318-644-0397
<b>Serial # ASXXXXXXXX</b>	
<b>Model # ASXXXX-XXX</b> <b>Class 1 Size XXXX GPD</b>	
<b>For service call your local service provider</b>	

*The above weatherproof vinyl label is permanently affixed to the aerator compressor*

# HIBLOW HP80-013A Compressor Alarm Module

## Operating Instructions

- ⚠ **Danger:** Do not attempt to open the alarm module. If the unit is connected to electricity, opening of the alarm module can result in a risk of electric shock.
- ⚠ **Danger:** Service of the alarm module should only be done by a qualified electrician or serviceman.
- ⚠ **Danger:** If the outside of the alarm module or light lens becomes cracked or damaged, unplug or shut-off the electric power immediately and contact an electrician or serviceman.
- ⚠ **Caution:** Do not carry the unit by the alarm module or electrical cord. It could damage the alarm module.

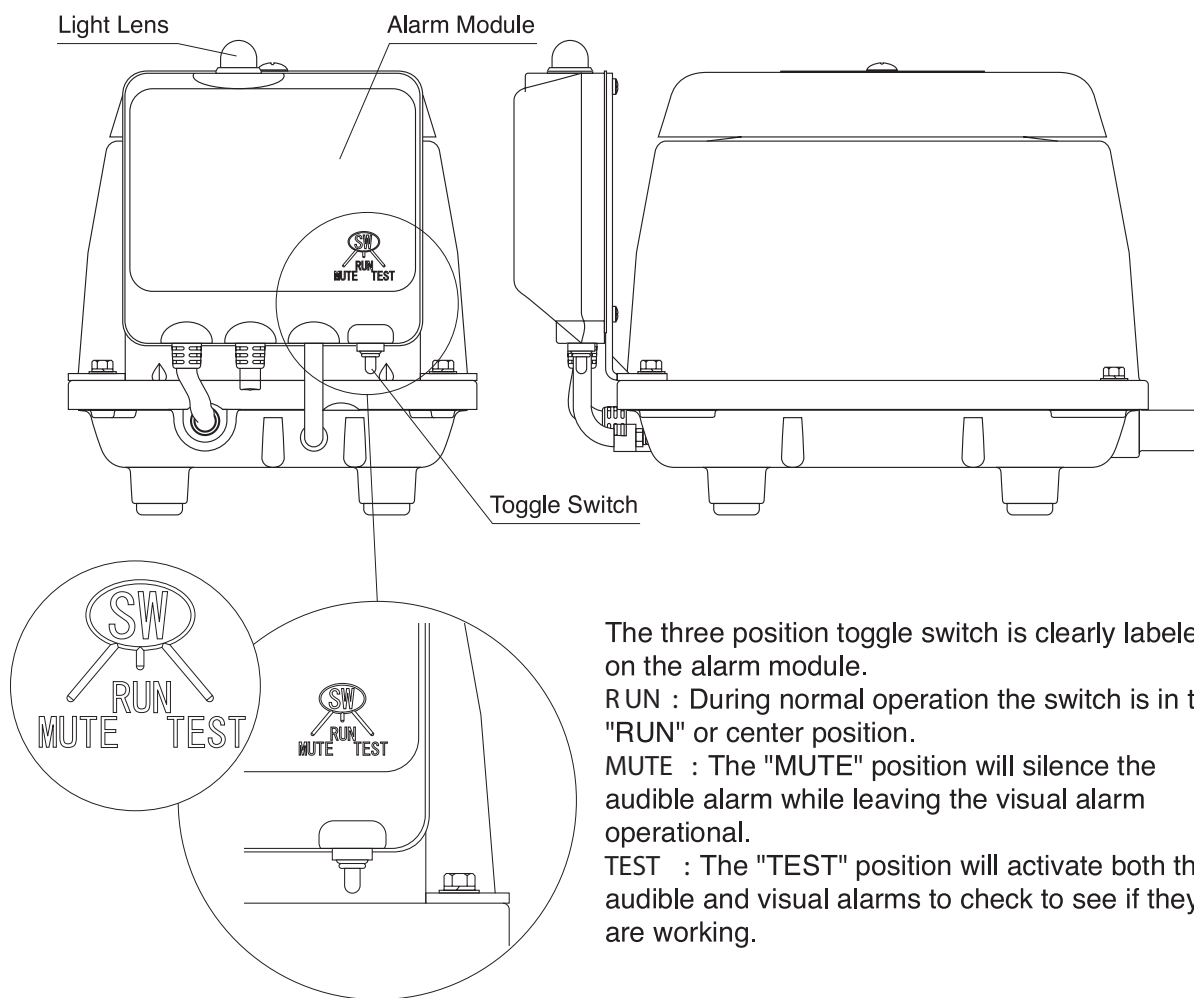

The three position toggle switch is clearly labeled on the alarm module.

**RUN** : During normal operation the switch is in the "RUN" or center position.

**MUTE** : The "MUTE" position will silence the audible alarm while leaving the visual alarm operational.

**TEST** : The "TEST" position will activate both the audible and visual alarms to check to see if they are working.

### In Case of an Alarm :

The alarm module audible alarm (buzzer) and visual alarm (light) are intended to signal a system malfunction. Contact your service provider whenever you hear or see the alarm when the switch is in the "RUN" or center position. The "MUTE" position can be used to silence the audible alarm until the service provider arrives.

# Aerobic Control AQUA SAFE®

## Installation Instructions and Operation/Troubleshooting Manual

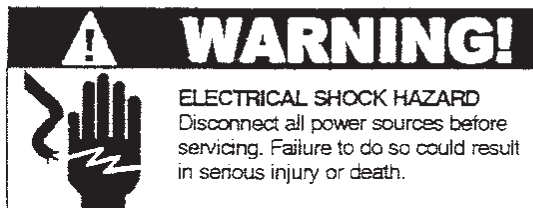

Control panels must be installed and serviced by a licensed electrician in accordance with the National Electric Code NFPA-70, state and local electrical codes.

All conduit running from the tank to the control panel must be sealed with conduit sealant to prevent moisture or gases from entering the panel.

### Installation

The aerobic treatment system panel is designed to operate an air compressor and effluent pump, in addition to providing air compressor fail and high water level alarm functions.

**NOTE:** Options ordered may affect the number of floats and their functions. Please reference the schematic provided with the control panel for proper installation.

#### Installation of Floats

**CAUTION:** If float switch cables are not wired and mounted in the correct order, the pump system will not function properly.

**WARNING:** Turn off all power before installing floats in pump chamber. Failure to do so could result in serious or fatal electrical shock.

1. Label floats for specific operation (high water alarm, pump on/off and timer override). See schematic for float options.
2. Determine your normal operating level as illustrated in Figure 1.
3. Mount float switches at appropriate levels via stationary device as illustrated in Figure 2 & 3. Be sure that floats have free range of motion without touching each other or other equipment in the basin.

#### Mounting the Control Panel

1. Determine mounting location for panel. If distance exceeds the length of either the float switch cables or the pump power cables, splicing will be required. For outdoor or wet installation, we recommend the use of a liquid-tight junction box with liquid-tight connectors to make required connections.

**AQUA SAFE®**

# Installation Instructions

2. Mount control panel.
3. Route 1/8" airline tubing from "T" at compressor manifold to control panel.
4. Slide 1/8" airline tubing over bulkhead connector on bottom of control panel.
5. Determine conduit entrance locations on control panel.

NOTE: Be sure the power supply voltage and phase are the same as the motors being installed. If in doubt, see the identification plates for voltage/phase requirements.

6. Knock out proper size holes for type of connectors being used.

NOTE: If using conduit, be sure that it is of adequate size to pull the pump and switch cables through.

7. Attach cable connectors and/or conduit connectors to control panel.

**FOR INSTALLATION REQUIRING A SPLICE,  
FOLLOW STEPS 8-11;  
FOR INSTALLATION WITHOUT A SPLICE,  
GO TO STEP 12.**

8. Determine location for mounting junction box according to state and local code requirements. Mount junction box to proper support. Do not mount the junction box inside the tank.
9. Run conduit to junction box. Drill proper size holes for the type of conduit used. Attach connectors to junction box.
10. Identify and label each wire before pulling through conduit into control panel and junction box. Make wire splice connections at junction box.
11. Firmly tighten all fittings on junction box.
12. If a junction box is not required, identify and label pump cable before pulling through conduit into control panel.
13. Connect pump and switch wires to terminals as seen on wiring diagram.
14. Connect "power-in" conductors to proper locations: 120 volt AC power (Hot (Li) and Neutral (N)) to terminals as seen on wiring diagram provided with control panel.

**VERIFY CORRECT OPERATION OF CONTROL PANEL  
AFTER INSTALLATION IS COMPLETE.**

NOTE: The compressor fail alarm will sound until the system has reached normal operating pressure.

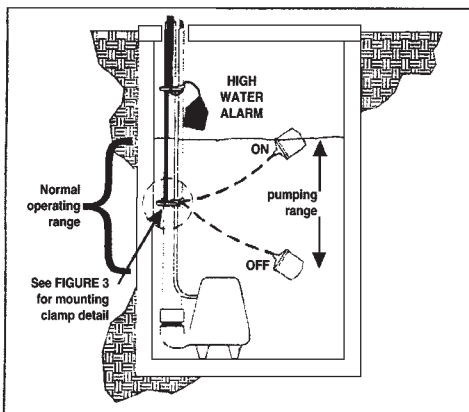

**FIGURE 1** -SJE wide angle\* float system  
\*Junior Super Single®  
(See chart below to determine pumping range)

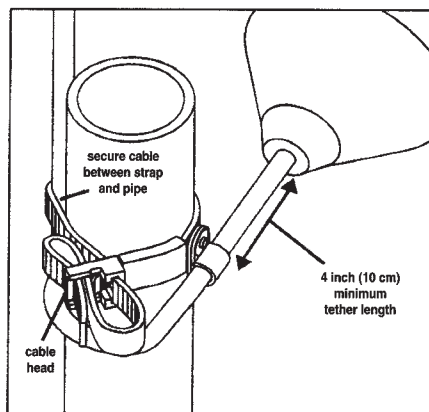

**FIGURE 2** -Pipe clamp mounting detail for high water alarm float

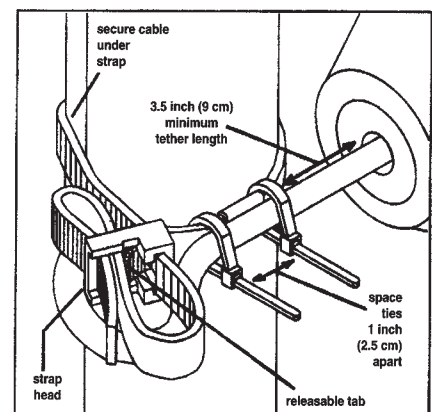

**FIGURE 3** -Pipe clamp mounting detail for pump on/off float.

## Determining Pumping Range in Inches (1 inch = 2.5 cm)

Use only as a guide. Pumping ranges are based on testing in non-turbulent conditions. Range may vary due to water temperature and cord shape.  
Note: As the tether length increases, so does the variance of the pumping range.

tether length	3.5	6	8	10	12	15	17
pumping range	6.5	8.5	11	13	14	17	19

**Junior Super Single®  
pumping range**

# Installation Instructions

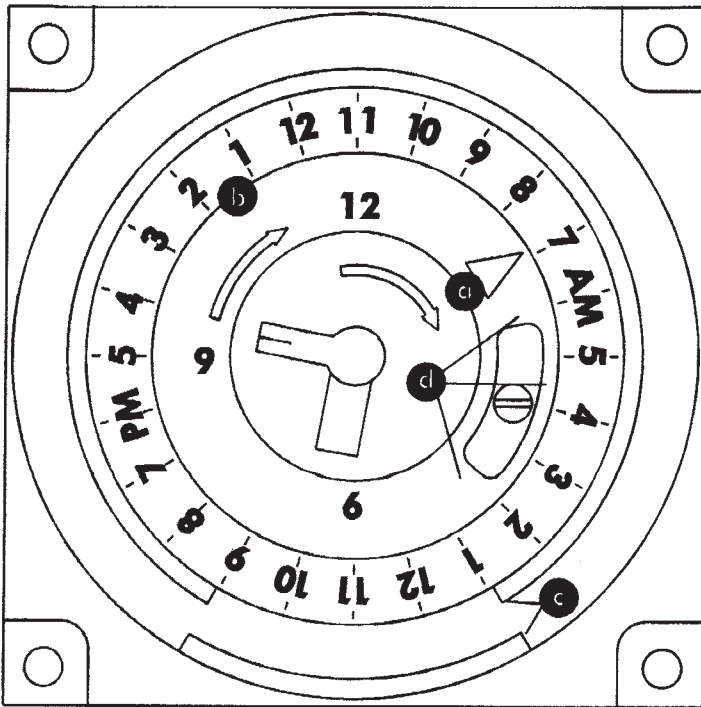

FIGURE 3 - Timer detail

## Setting the timer (optional)

The timer is a 24 hour time clock with 15 minute increment settings. The captive trippers change the SPDT relay state when pushed toward the outside.

### 1. Setting time of day

(a) Synchronize the timer by aligning arrow at the 2:00 position of inner face with the corresponding time of day printed on the outer ring. NOTE: Power must be ON to keep time synchronization.

### 2. Setting ON time and duration

Locate desired activation time(s) on outer ring (b) and push trippers to the outside (c). Each tripper represents 15 minutes activation time. Push as many trippers back as desired for duration time. When the timer reaches the first tripper, the timer SPDT contacts will change state and turn ON. It will remain ON for as long as the following trippers are pushed out. When timer goes past last tripper, the timer will return to the OFF mode. The timer has a selector for (d) OFF (O), AUTOMATIC (blank), and MANUAL OVERRIDE (I) modes.

# Operations

The Aqua Safe aerobic control was designed to operate a single-phase air compressor and effluent pump. The control incorporates an audio/visual alarm for high water conditions and air compressor fail. A test/normal/silence switch, which is located on the side of the enclosure, allows the user to test the alarm horn and light, or silence the horn while keeping visual indication. The alarm indication will remain active until the condition is cleared. The high water alarm is activated via a normally open float switch. The air compressor fail alarm is activated either by a circuit breaker trip or a low air pressure condition.

NOTE: If the horn is silenced in an alarm condition, the switch must be returned to the "normal" or center position once the problem has been cleared.

The alarm circuit, compressor circuit, and effluent pump circuit each contain a thermal-magnetic circuit breaker for branch circuit protection and disconnect.

Certain models of the aerobic control utilize a 24-hour timer to control the effluent pump. The effluent pump is controlled by a pump switch for dosing sizes and a timer for selecting periods of the day to allow dosing or spraying. A timer override float may be included as an option to allow dosing/spraying in high demand situations.

## Model 103 Field Wiring Diagram

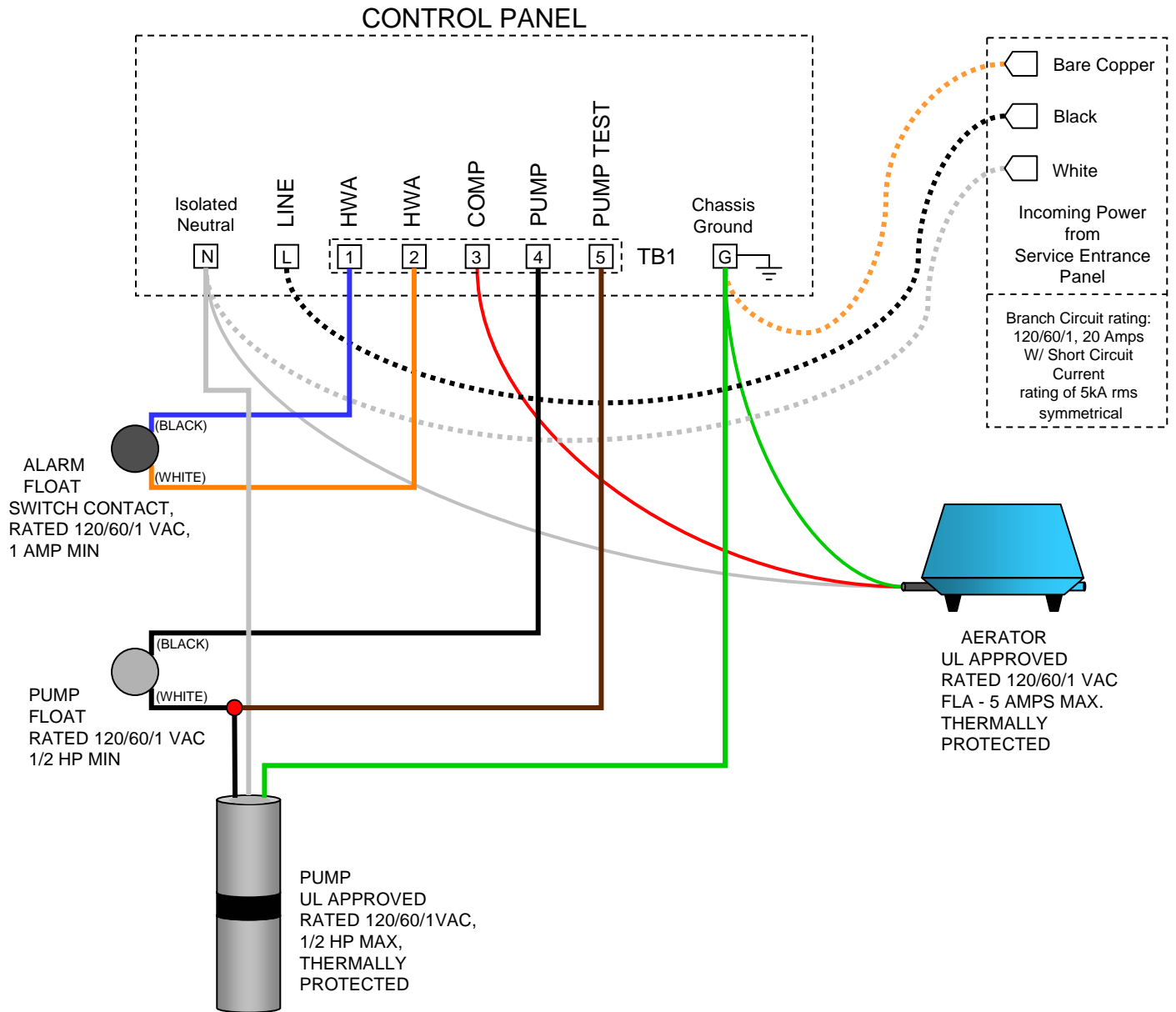

### Notes for field installed components:

1. Main Disconnect, Branch Circuit Protection, wiring and external components to be provided by installer.
2. Field wiring - #12 – #10 AWG, 60°C min, use copper conductors only.
3. Field installed conduit fittings must be rated for use with Type 3R Enclosure.
4. Torque Terminal Block, Neutral and Ground screws to 15 – 20 in-lbs.
5. **Conduit openings must be sealed around wiring with an electrical grade (non-corrosive) sealant to prevent potentially harmful vapors from entering the control panel.**

# Model 103 Schematic Diagram

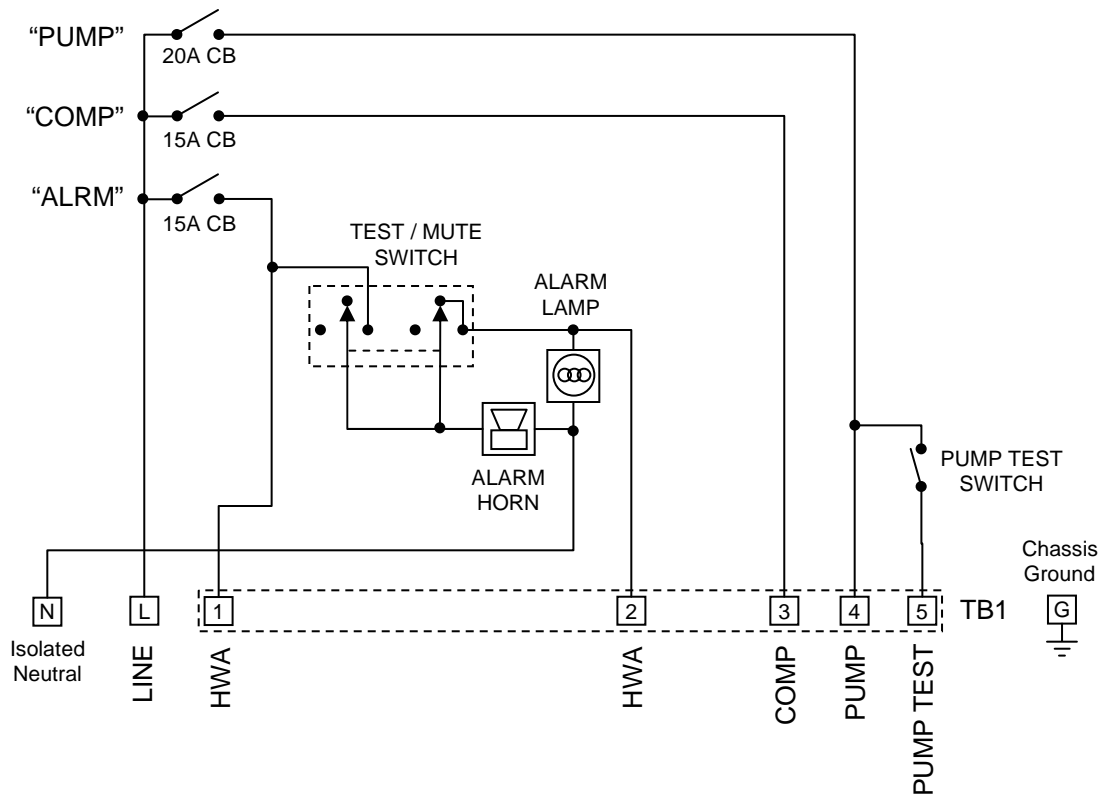

# Model 105 (Metal Demand) Field Wiring Diagram

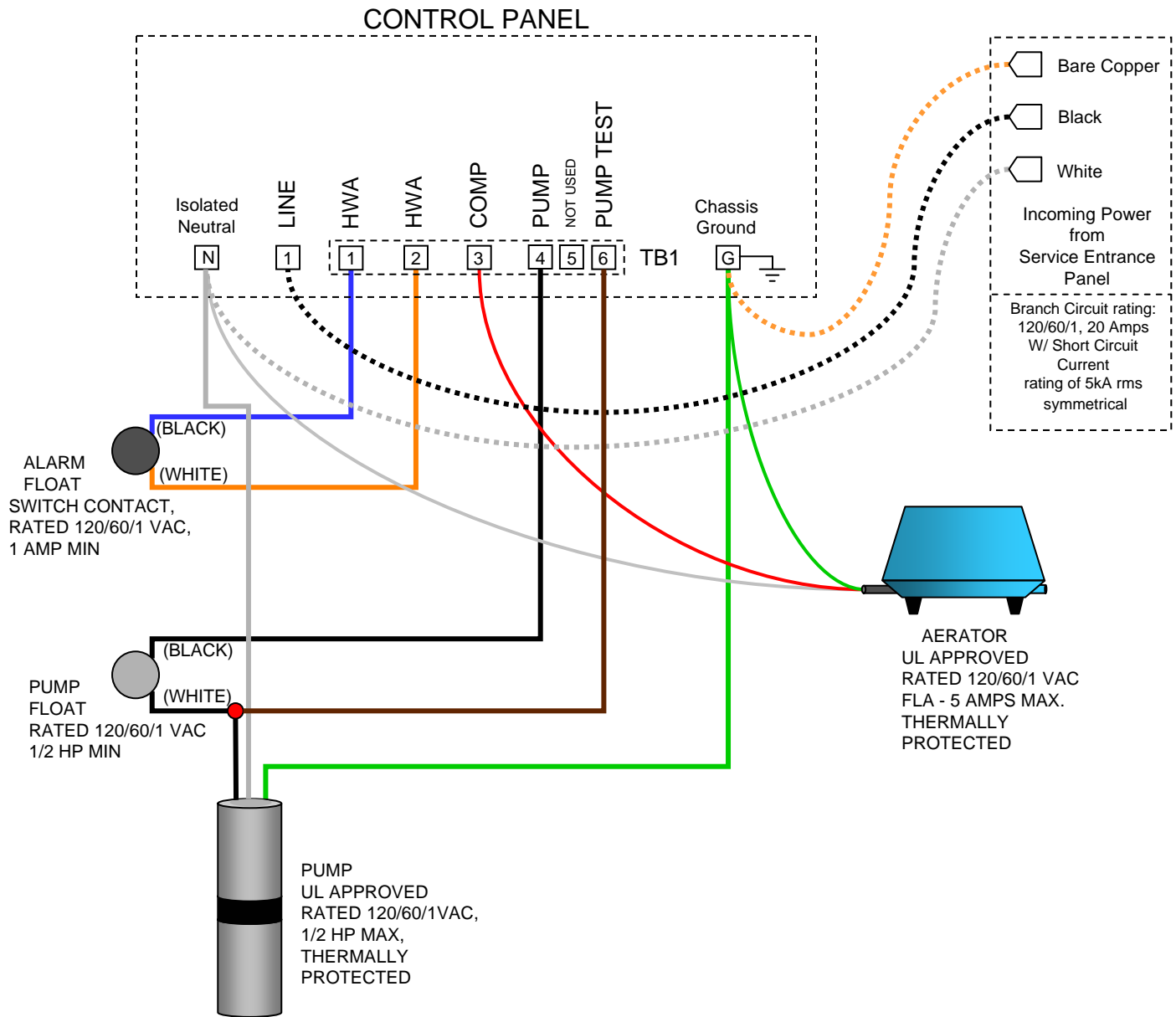

## Notes for field installed components:

1. Main Disconnect, Branch Circuit Protection, wiring and external components to be provided by installer.
2. Field wiring - #12 – #10 AWG, 60°C min, use copper conductors only.
3. Field installed conduit fittings must be rated for use with Type 3R Enclosure.
4. Torque Terminal Block, Neutral and Ground screws to 15 – 20 in-lbs.
5. **Conduit openings must be sealed around wiring with an electrical grade (non-corrosive) sealant to prevent potentially harmful vapors from entering the control panel.**

# Model 105 (Metal Demand) Schematic Diagram

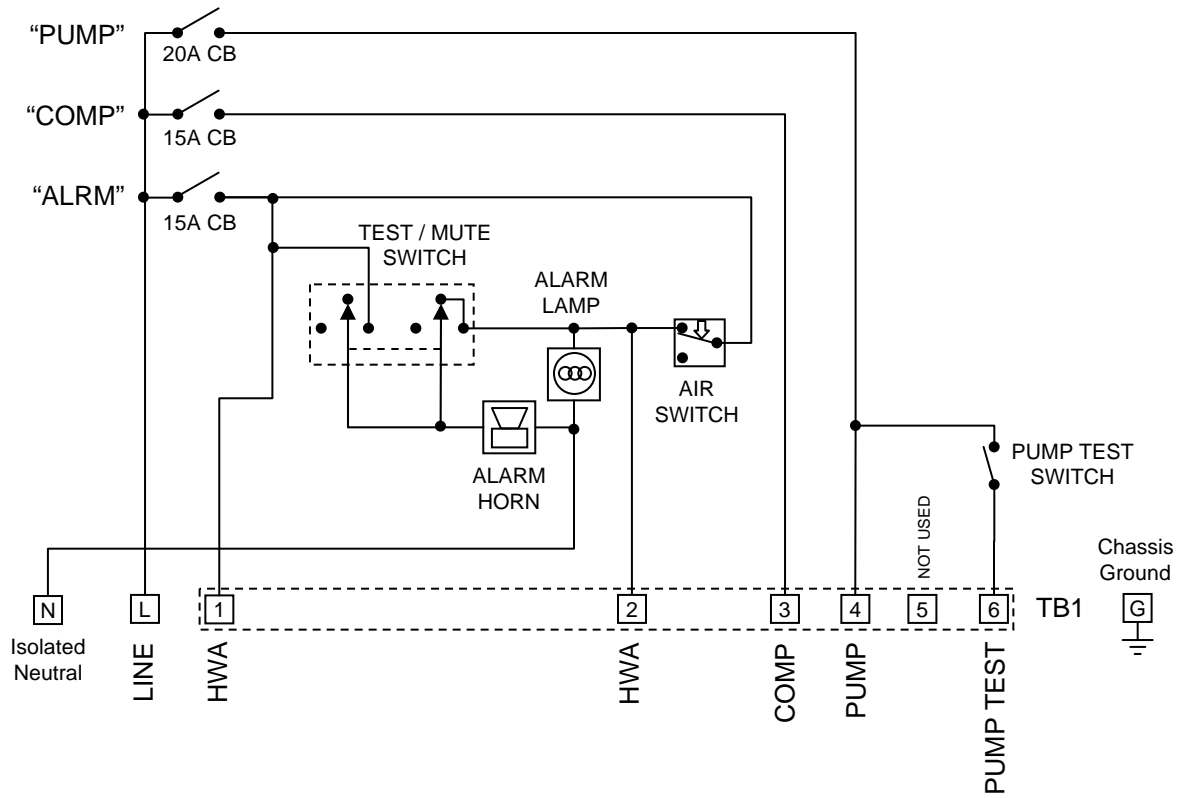

# Model 106 (Metal Timed) Field Wiring Diagram

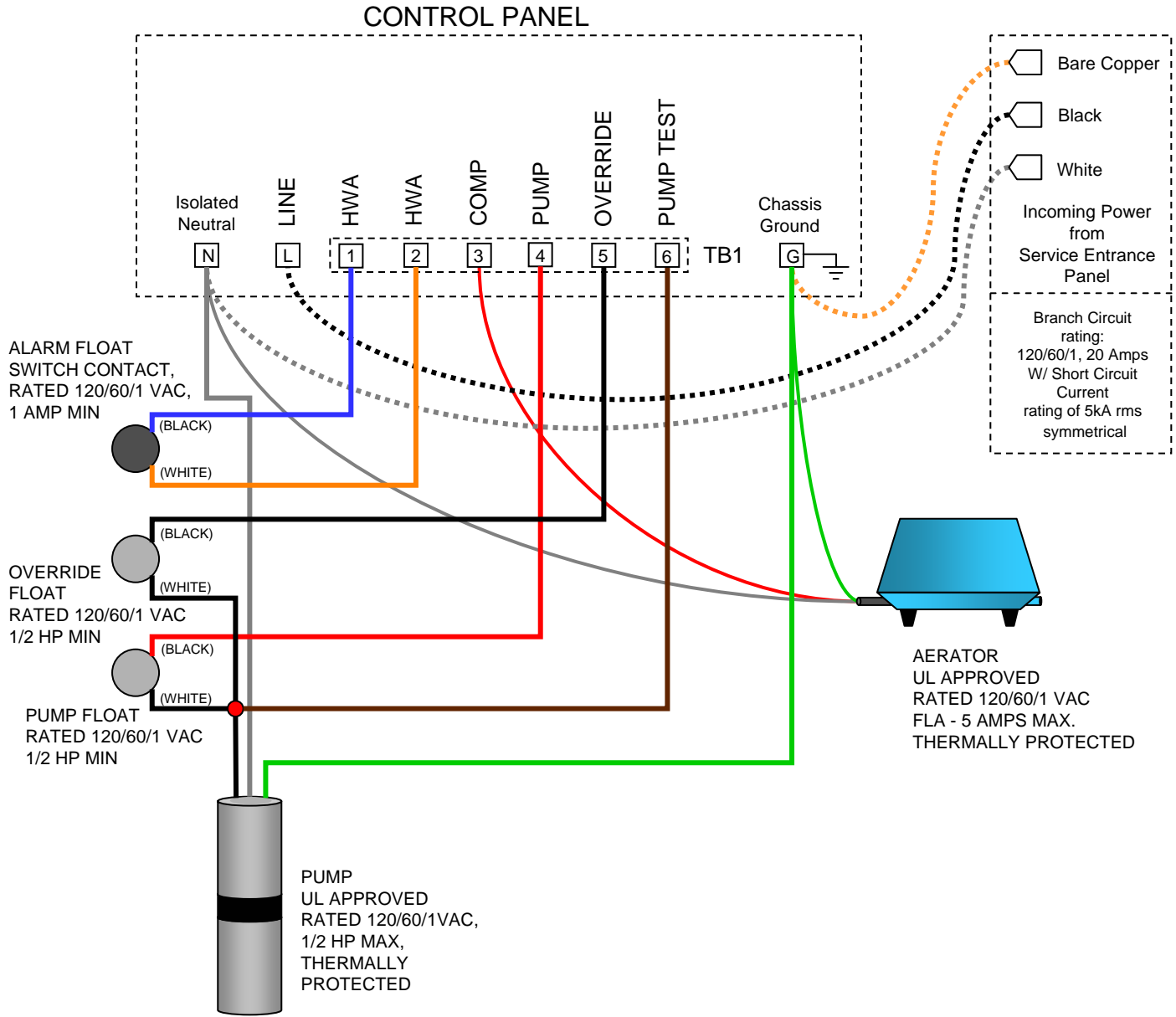

## Notes for field installed components:

1. Main Disconnect, Branch Circuit Protection, wiring and external components to be provided by installer.
2. Field wiring - #12 – #10 AWG, 60°C min, use copper conductors only.
3. Field installed conduit fittings must be rated for use with Type 3R Enclosure.
4. Torque Terminal Block, Neutral and Ground screws to 15 – 20 in-lbs.
5. **Conduit openings must be sealed around wiring with an electrical grade (non-corrosive) sealant to prevent potentially harmful vapors from entering the control panel.**



# Model 202 (Poly Demand) Field Wiring Diagram

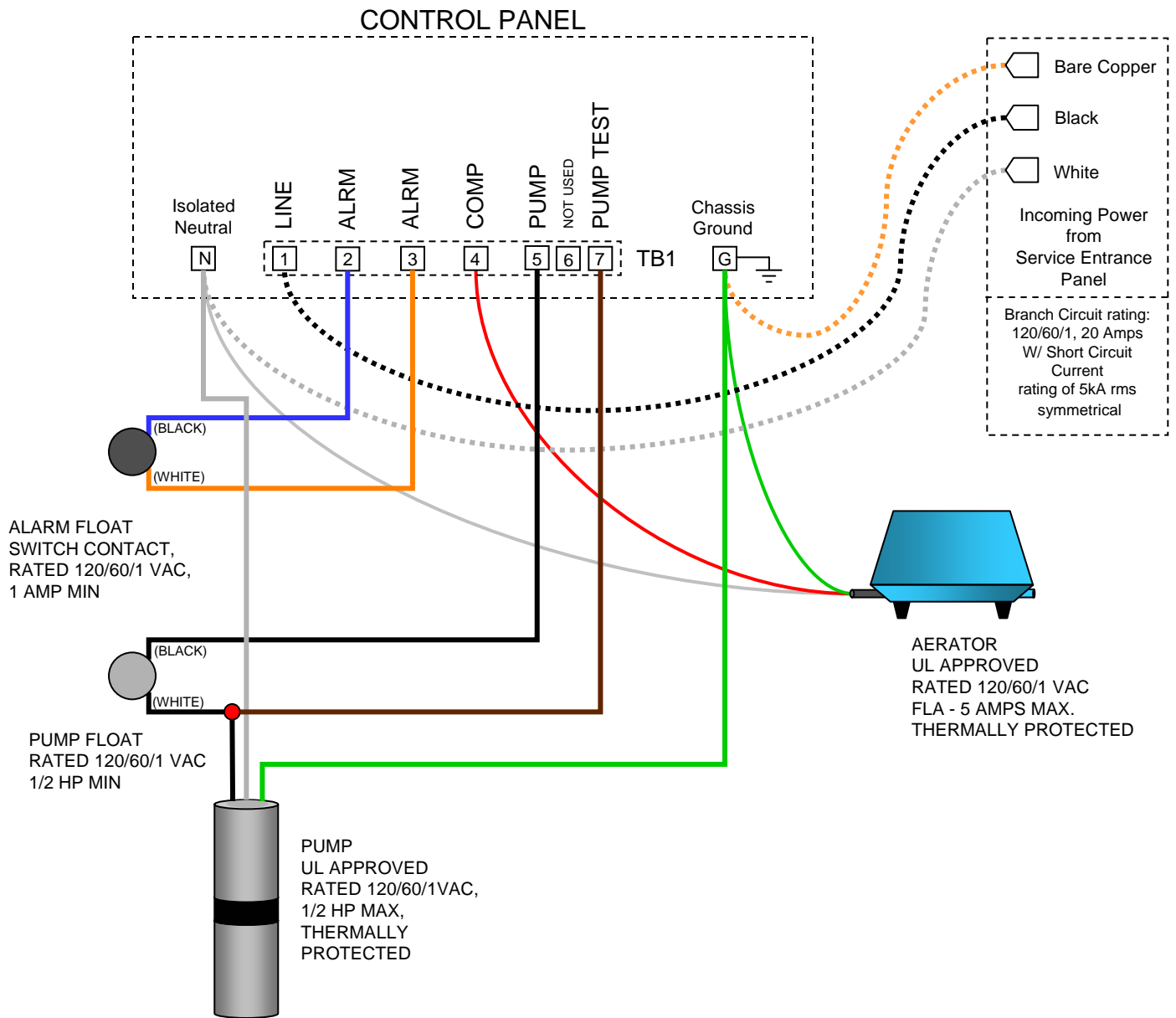

## Notes for field installed components:

1. Main Disconnect, Branch Circuit Protection, wiring and external components to be provided by installer.
2. Field wiring - #12 – #10 AWG, 60°C min, use copper conductors only.
3. Field installed conduit fittings must be rated for use with Type 4X Enclosure.  
If used, metal conduit fittings must provide means to bond conduit to ground terminal.
4. Torque Terminal Block, Neutral and Ground screws to 15 – 20 in-lbs.
5. **Conduit openings must be sealed around wiring with an electrical grade (non-corrosive) sealant to prevent potentially harmful vapors from entering the control panel.**

# Model 202 (Poly Demand) Schematic Diagram

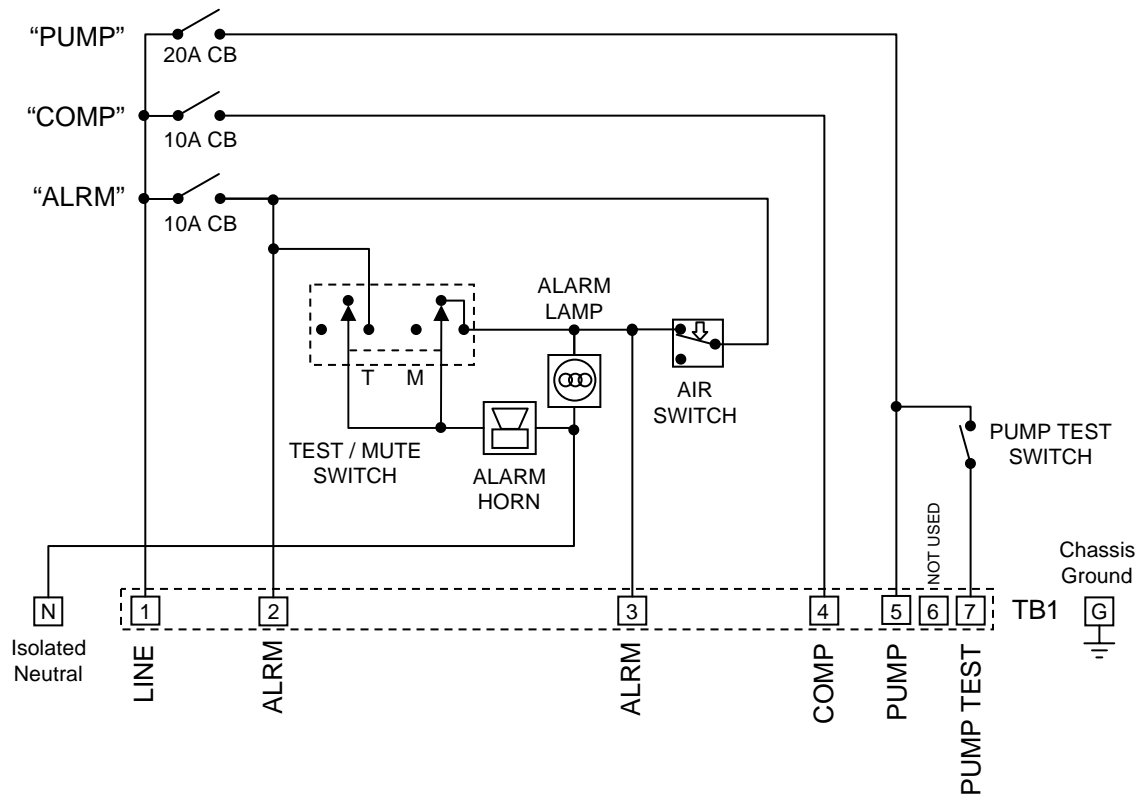

# Model 203 (Poly Timed) Field Wiring Diagram

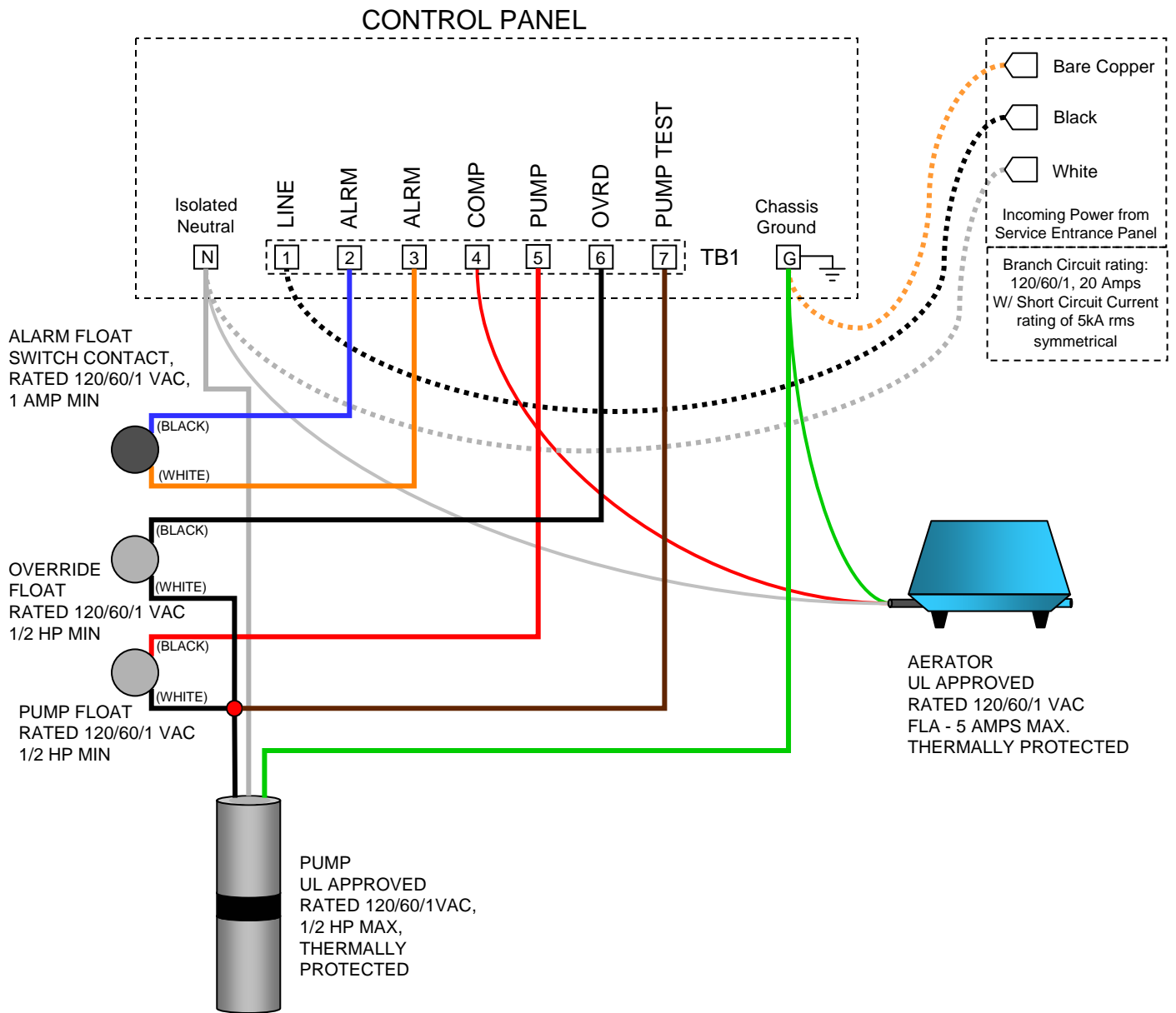

## Notes for field installed components:

1. Main Disconnect, Branch Circuit Protection, wiring and external components to be provided by installer.
2. Field wiring - #12 – #10 AWG, 60°C min, use copper conductors only.
3. Field installed conduit fittings must be rated for use with Type 4X Enclosure.  
 If used, metal conduit fittings must provide means to bond conduit to ground terminal.
4. Torque Terminal Block, Neutral and Ground screws to 15 – 20 in-lbs.
5. **Conduit openings must be sealed around wiring with an electrical grade (non-corrosive) sealant to prevent potentially harmful vapors from entering the control panel.**

# Model 203 (Poly Timed) Schematic Diagram

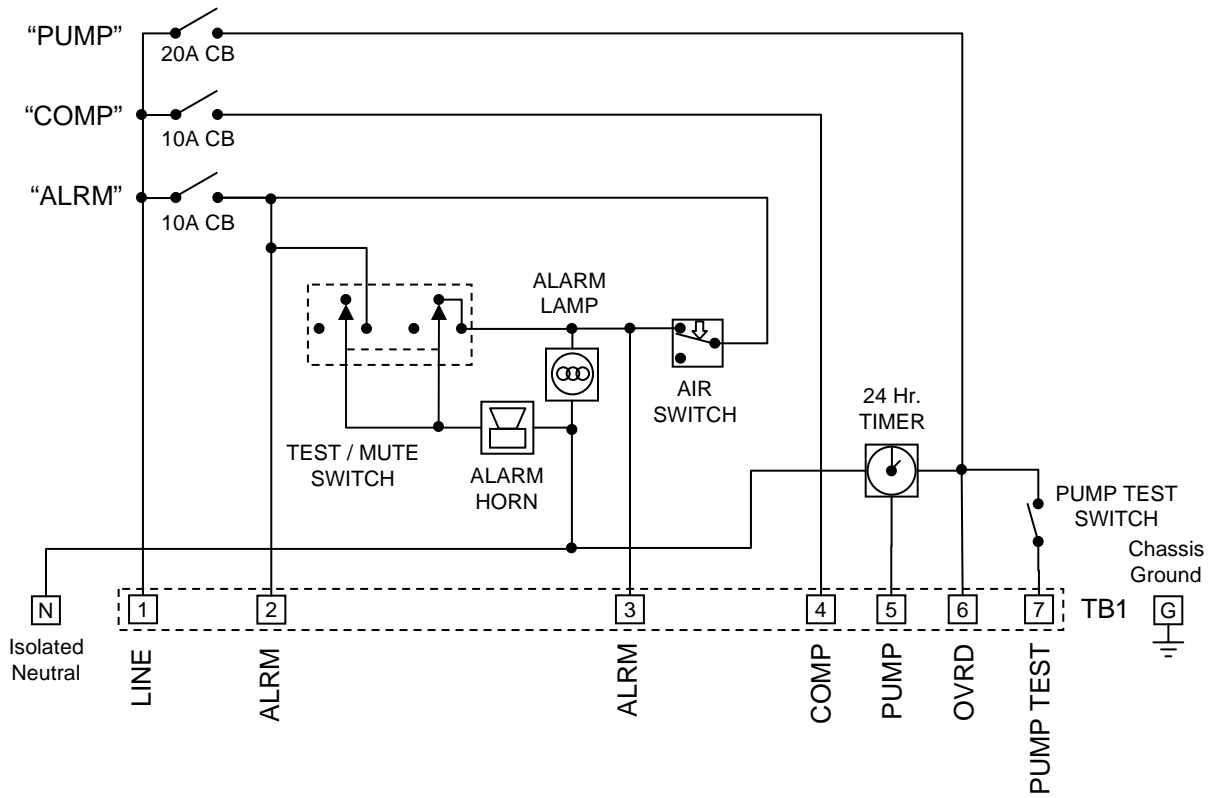

# MODEL 206 Field Wiring Diagram CONTROL PANEL

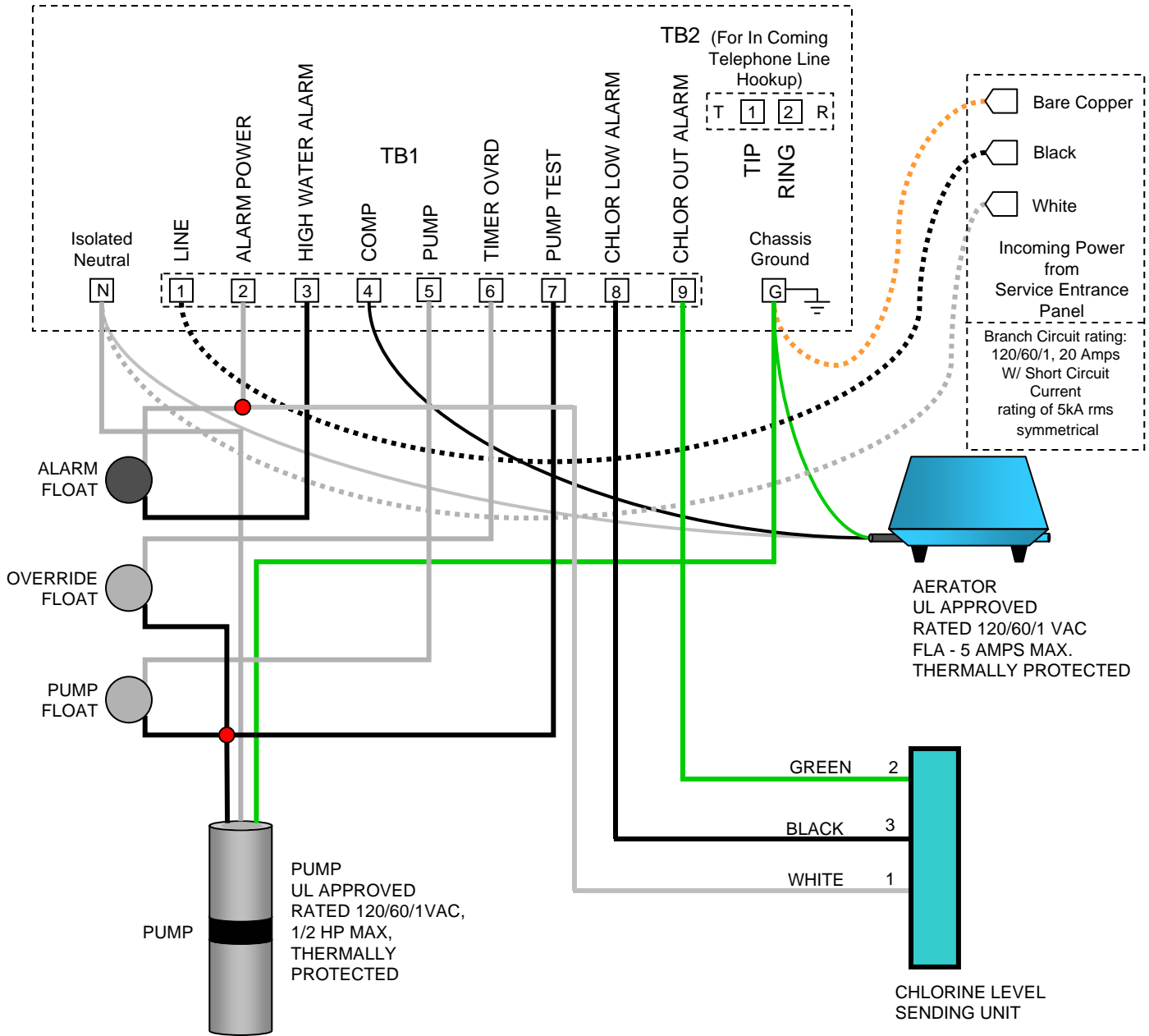

## Notes for field installed components:

1. Main Disconnect, Branch Circuit Protection, wiring and external components to be provided by installer.
2. Field wiring - #12 – #10 AWG, 60°C min, use copper conductors only.
3. Field installed conduit fittings must be rated for use with Type 4X Enclosure.  
If used, metal conduit fittings must provide means to bond conduit to ground terminal.
4. Torque Terminal Block, Neutral and Ground screws to 15 – 20 in-lbs.
5. **Conduit openings must be sealed around wiring with an electrical grade (non-corrosive) sealant to prevent potentially harmful vapors from entering the control panel.**



## Model 227 / RDPA Field Wiring Diagram

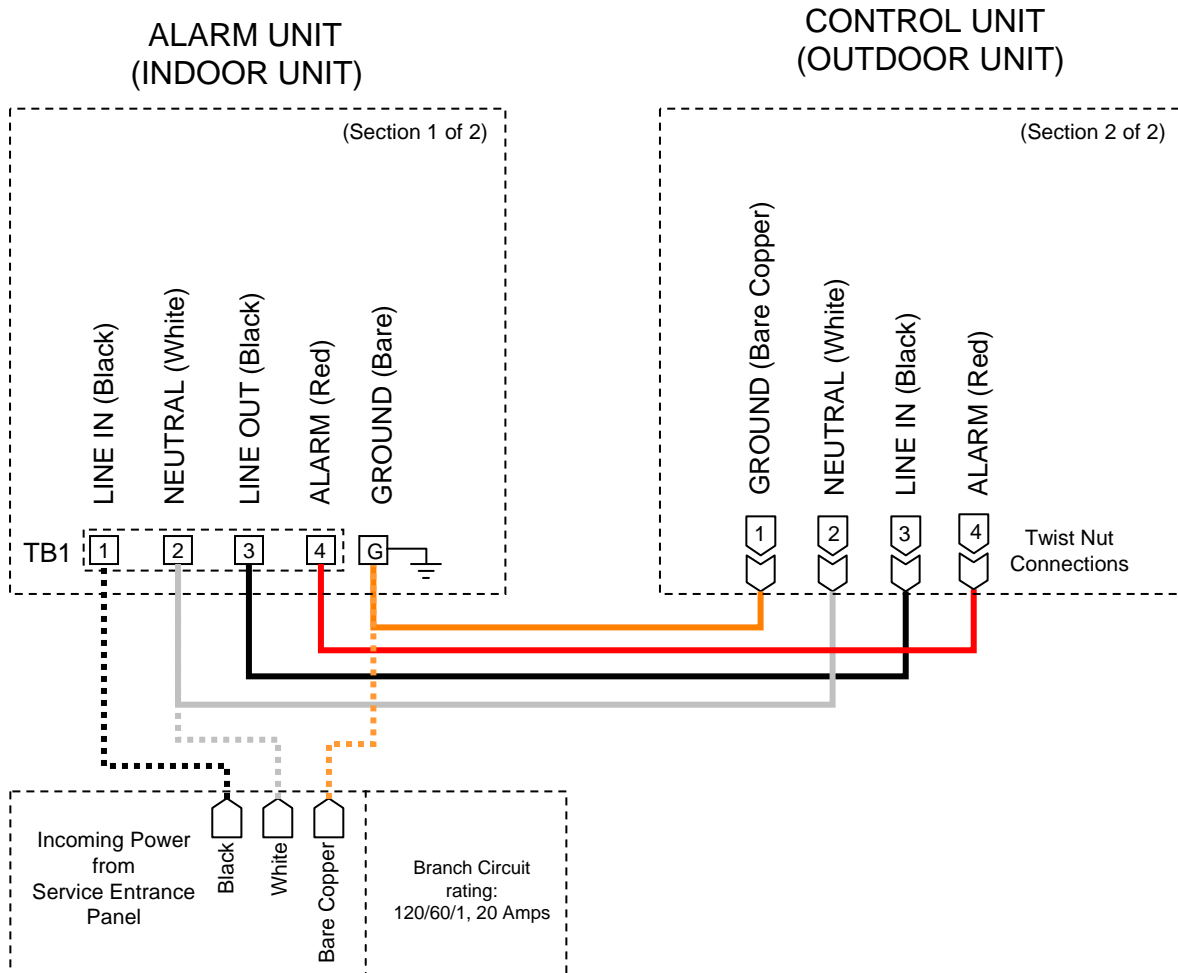

### Notes for field installed components:

1. Main Disconnect, Branch Circuit Protection, wiring and external components to be provided by installer.
2. Field wiring - #12 – #10 AWG, 60°C min, use copper conductors only.
3. External components (compressor and/or pumps) supplied by others and must be U. L. approved thermally protected motors.
4. Torque Terminal Block, Neutral and Ground screws to 15 – 20 in-lbs.
5. **Conduit openings must be sealed around wiring with an electrical grade (non-corrosive) sealant to prevent potentially harmful vapors from entering the control panel.**

# Model 227 / RDPA Schematic Diagram

(Section 2 of 2)  
**ALARM UNIT  
(INDOOR UNIT)**

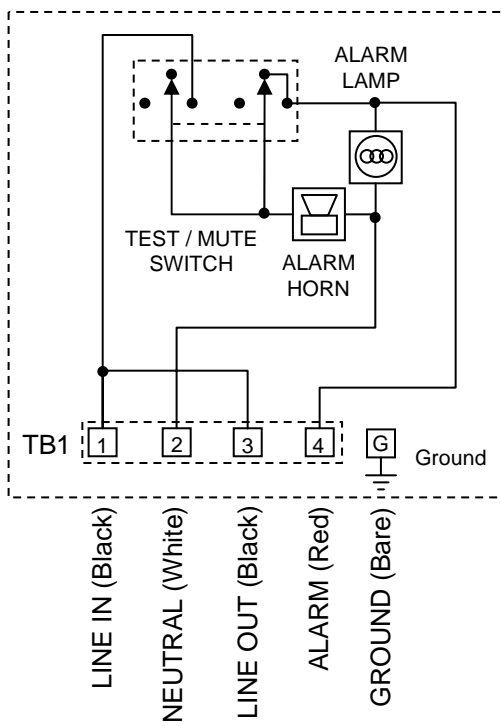

(Section 1 of 2)  
**CONTROL UNIT  
(OUTDOOR UNIT)**

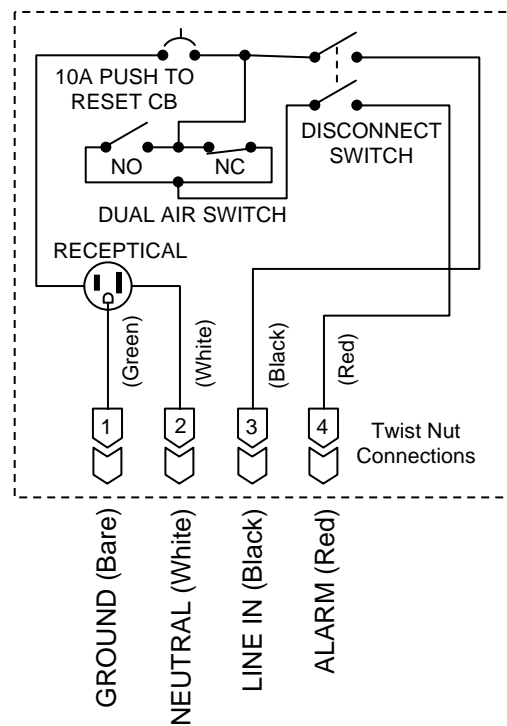

# Model RAB BASIC Field Wiring Diagram

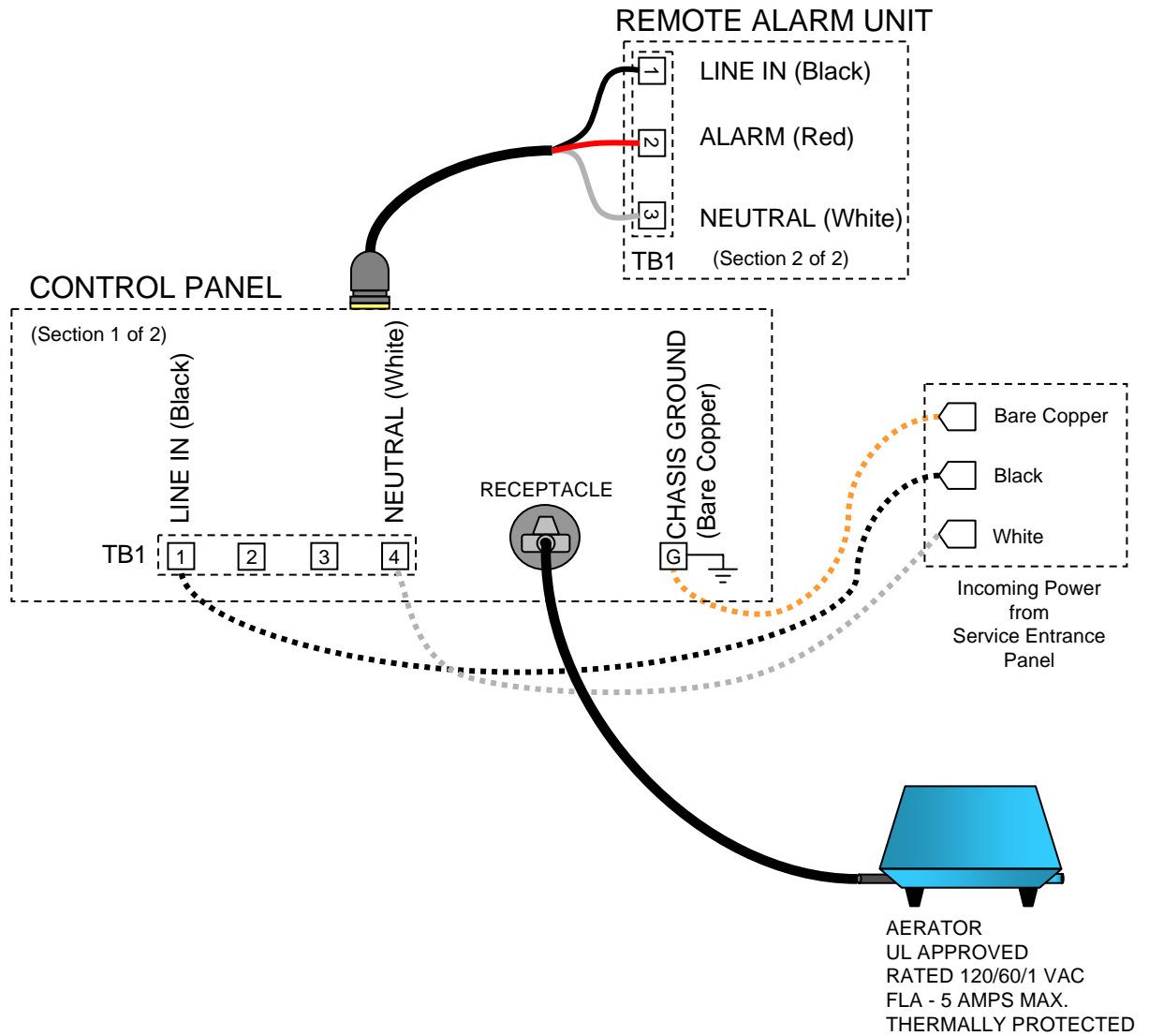

## Notes for field installed components:

1. Main Disconnect, Branch Circuit Protection, wiring and external components to be provided by installer.
2. Field wiring - #12 – #10 AWG, 60°C min, use copper conductors only.
3. Field installed conduit fittings must be rated for use with Type 4X Enclosure.
4. Torque Terminal Block, Neutral and Ground screws to 15 – 20 in-lbs.
5. **Conduit openings must be sealed around wiring with an electrical grade (non-corrosive) sealant to prevent potentially harmful vapors from entering the control panel.**

# Model RAB BASIC Schematic Diagram

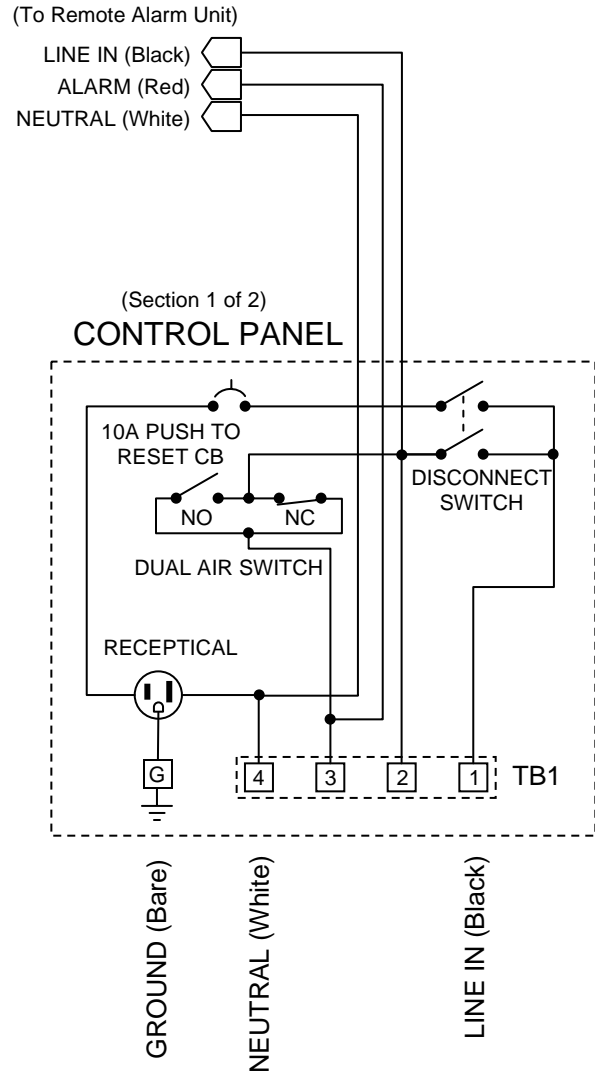
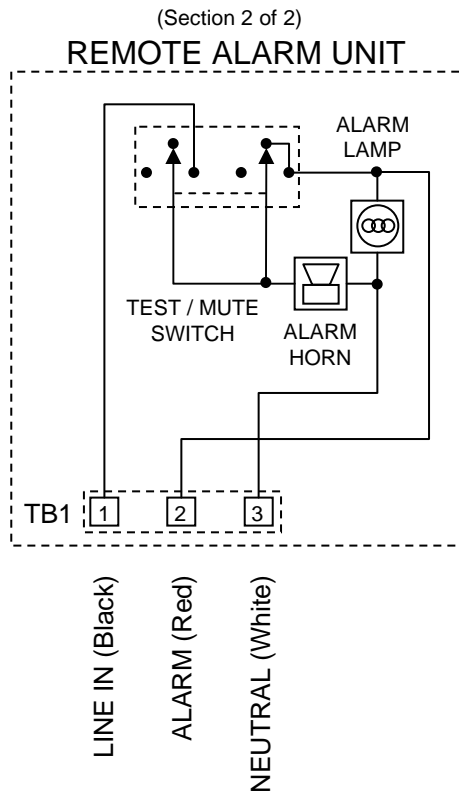

# MODEL DRP-1, 120VAC DRIP CONTROL PANEL, SINGLE FIELD, Field Wiring Diagram

Software version DRP-0001-0000

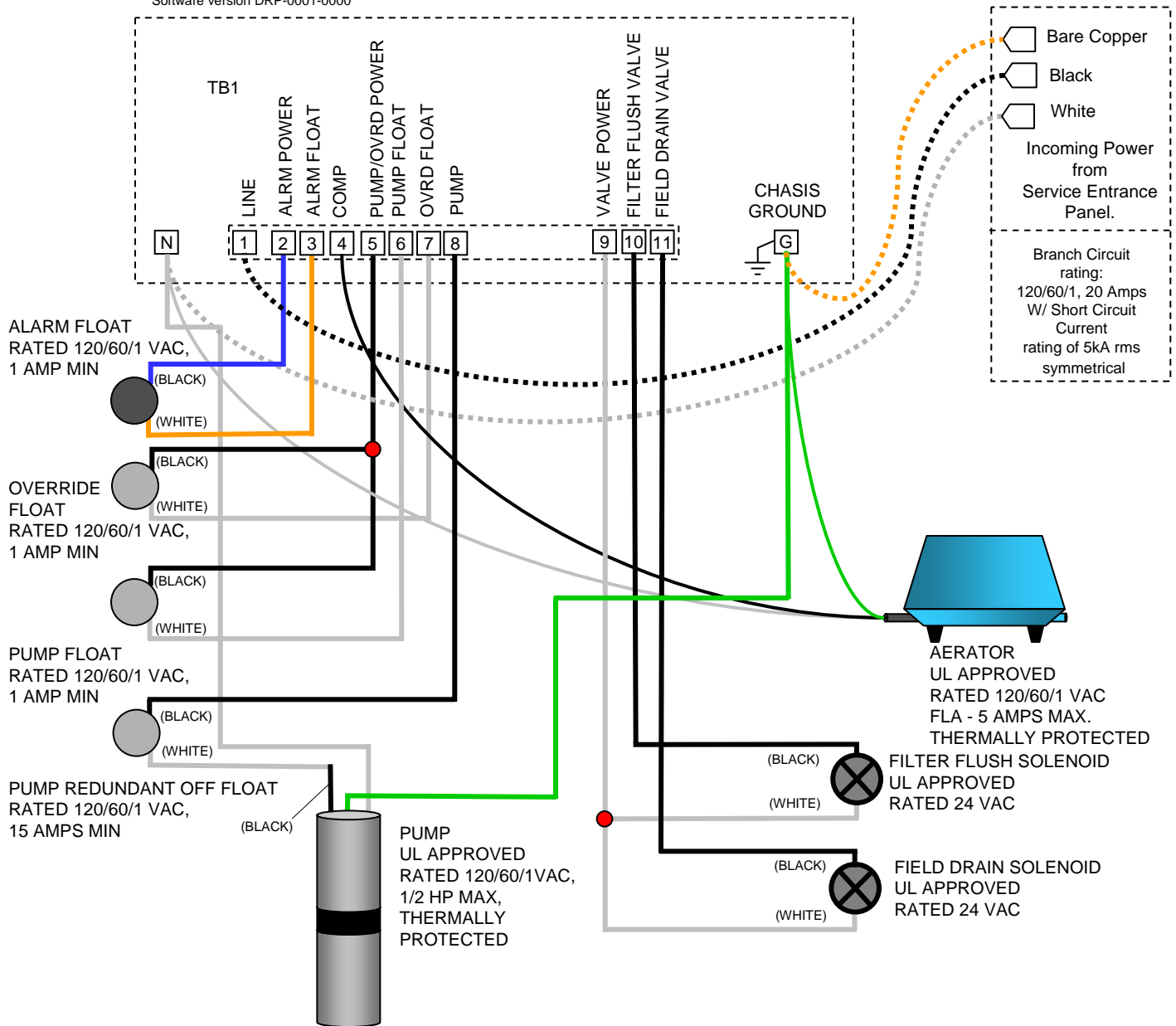

## Notes for field installed components:

1. Main Disconnect, Branch Circuit Protection, wiring and external components to be provided by installer.
2. Field wiring - #12 – #10 AWG, 60°C min, use copper conductors only.
3. Field installed conduit fittings must be rated for use with Type 4X Enclosure.  
If used, metal conduit fittings must provide means to bond conduit to ground terminal.
4. Torque Terminal Block, Neutral and Ground screws to 15 – 20 in-lbs.
5. **Conduit openings must be sealed around wiring with an electrical grade (non-corrosive) sealant to prevent potentially harmful vapors from entering the control panel.**

# MODEL DRP-1, 120 VAC, DRIP CONTROL PANEL, SINGLE FIELD, Schematic

Software version DRP-0001-0000

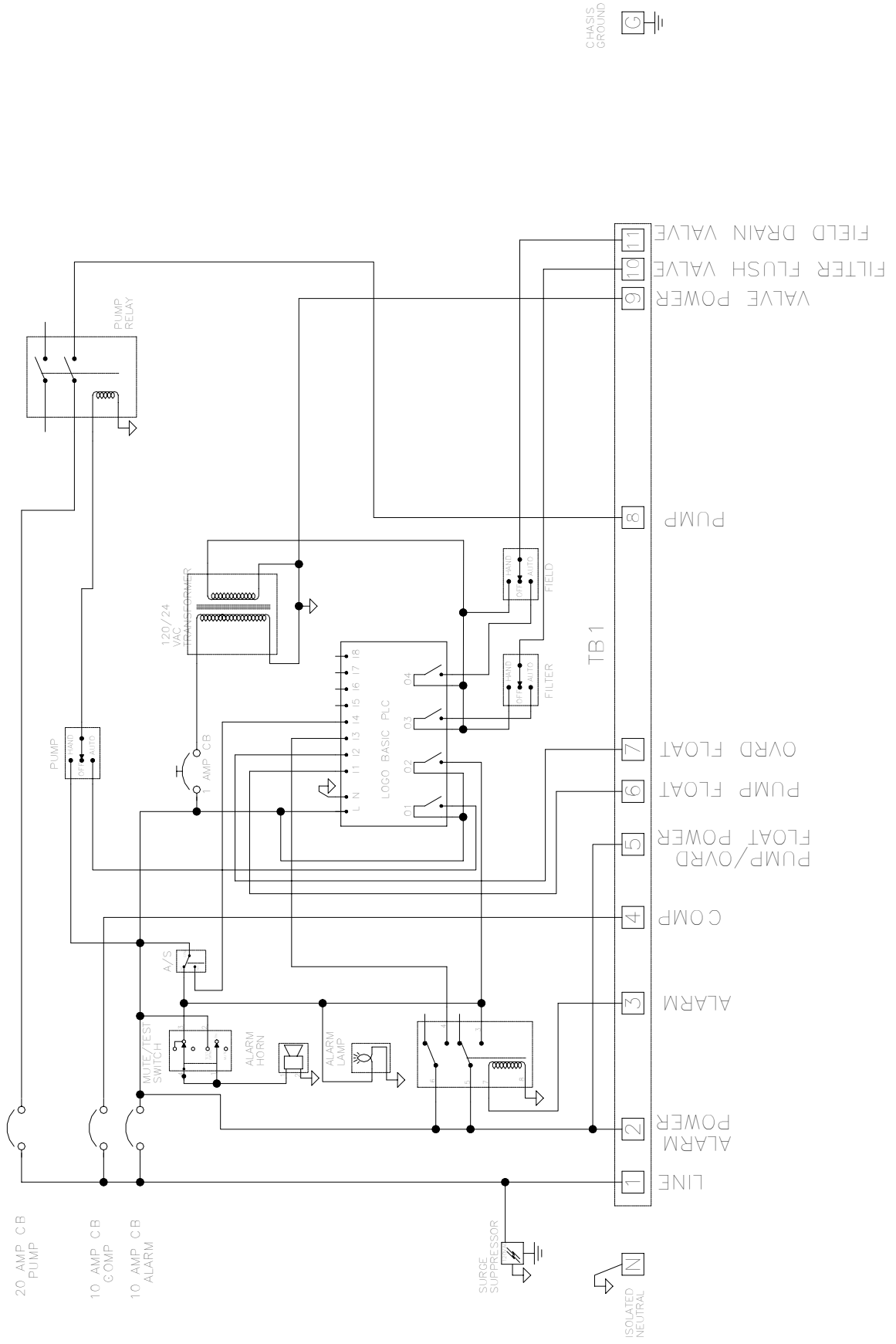

## **TROUBLESHOOTING**

**NOTE: Power must be on to test horn and alarm light.**

### **Alarm Horn**

Pressing the alarm test switch, turning the compressor circuit breaker OFF, or activating the alarm float should turn on the alarm horn. If the horn does not sound, replace with horn of same type.

### **Alarm Light**

Pressing the alarm test switch, activating the alarm float, or turning the compressor circuit breaker off should turn on the alarm light. If the light does not activate, replace bulb with the same type.

### **Circuit Breakers**

Check the circuit breaker for proper resistance reading using the following procedure.

1. With power OFF, isolate the circuit breaker by disconnecting the load side wires.
2. Place the ohmmeter leads across the corresponding line and load terminals.
3. With the ohmmeter on the R X 1 scale and the breaker in the OFF position, the reading should be infinity (very high resistance). With the breaker in the ON position, the reading should be nearly zero ohms (very low resistance). If the readings are not as stated, replace the circuit breaker with one of the same ratings.

**NOTE:** Readings may vary slightly depending on the accuracy of the measuring device.

### **Air Switch**

If lamp and horn are on and pump in pump tank is performing normal:

1. Disconnect air line at fitting at bottom of control panel and feel for air coming out of line.
2. If air supply is normal, then air switch is malfunctioning. Replace switch through manufacturers stock.

### **24 Hr. Clock Timer**

Clock not running

1. Check for input power to the control panel.
2. Check all terminals for secure connections.
3. Check breaker for on position.
4. If no circuit fault is evident, replace clock. Clock may be obtained through manufacturers immediate stock.

### **Pump Test Switch**

Switch not working

1. Turn OFF power. Disconnect both leads to the switch.
2. Connect one test lead from an OHM meter set on RX1 to one post on the pump test switch.
3. Connect the other lead from the same OHM meter to the other post of the pump test switch.
4. Pull on the toggle of the pump test switch.

Note: The meter needle should deflect across the entire scale. If the needle does not deflect or

reads open, replace the switch with one of the same type and rating.

### **Test / Mute Switch**

Switch not working.

1. Turn OFF power. Disconnect all leads from the test/mute switch.
2. Connect one lead from an OHM meter set on RX1 to the center post on circuit 1.
3. Connect the other lead from the OHM meter to the lower or second post in circuit 1.
  - A. With the toggle in the off or mute position there should be no deflection of the needle on the OHM meter.
  - B. With the toggle in the center position, the needle on the OHM meter should deflect across the entire scale.
  - C. By pulling the toggle into the “test” position the needle on the OHM meter should stay in the full deflection position.
4. Disconnect both leads from the switch
5. Connect one lead from an OHM meter set to RX1 to the center post of circuit 2 on the “test/mute” switch.
6. Connect the other lead from the same OHM meter to the lower or second post of circuit 2.
  - A. With the toggle on the off or mute position there should be no deflection of the needle on the OHM meter.
  - B. With the toggle in the center or normal position there should be no deflection of the needle on the OHM meter.
  - C. By pulling the toggle into the “test” position, the needle on the OHM meter should deflect across the entire scale.

**NOTE:** If results other than those just described are attained, replace the test/mute switch.

### **Float Controls**

Check the floats throughout their entire range of operation. Clean, adjust, or replace damaged floats.

Check the float resistance - The float resistance can be measured to determine if the float is operating correctly or is defective. Use the following procedure to measure the float resistance:

1. Isolate the float by disconnecting one or both of the float leads from the float terminals.
2. Place one Ohmmeter lead on one of the float wires, and the other ohmmeter lead on the other float wire.
3. Set the ohmmeter dial to read ohms and place on the RX1 scale. With the float in the OFF position the scale should read infinity (very high resistance). Replace the float if you do not get this reading. With the float in the ON position the scale should read nearly zero (very low resistance). Replace float if you do not get this reading.

**NOTE:** Readings may vary slightly depending on the length of wire and accuracy of the measuring device.

**CAUTION: IT IS IMPORTANT TO CONNECT LINE(1) IN THE JUNCTION BOX TO THE H.W.A.(1) IN THE CONTROL PANEL AND LINE(2) IN THE JUNCTION BOX TO THE H.W.A.(2) IN THE CONTROL PANEL.**

# INSTRUCTIONS FOR Chlorine EWDS (Early Warning Detection System)

Patent Pending

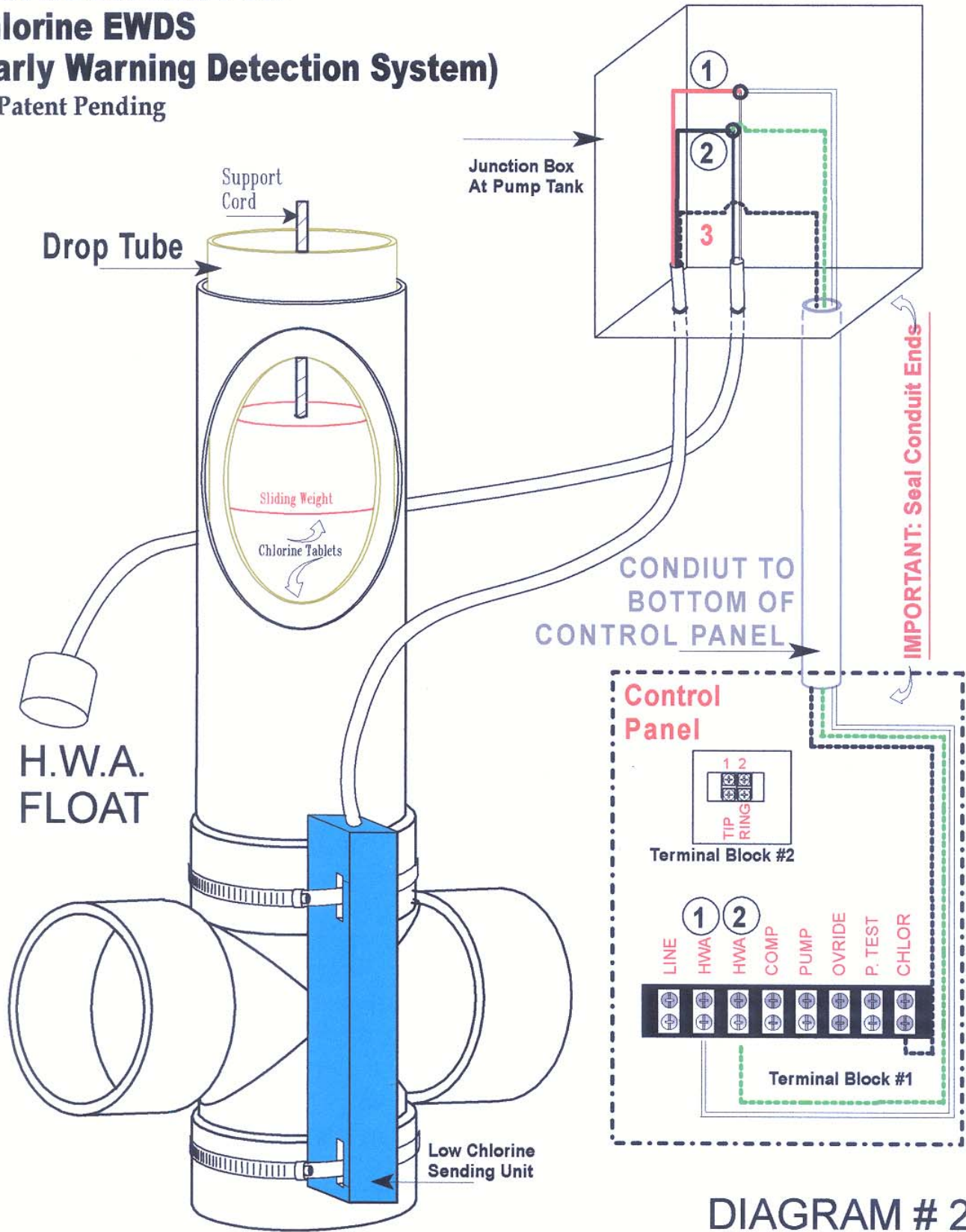

DIAGRAM # 2

## AERATOR SPECIFICATIONS

**Aqua Safe®** aerators for use with all models:

All aerators listed are 115 Volt, 60 Hertz and Single Phase

**Models: AS500, AS500-5 Pre, AS500-5 Pump, AS500-4+75, AS500EZ  
AS500 TRIO, AS500CU, AS500-300, AS500+5 pre, AS500+5 pump, AS500-300CU**

**Aqua Safe® 500 gpd Designation - ASC2532**

HiBlow Model HP80- Linear - 2.0 amps / 76 watts / 3.9 CFM open flow  
SECOH Model EL80-15 - Linear - 2.6 amps / 106 watts / 3.4 CFM open flow  
GAST Model RV03 - Rotary – 3.0 amps / 120 watts / 3.8 CFM open flow

**Model AS600, AS600CU, AS600-300, AS600EZ; AS600 TRIO**

**Aqua Safe® 600 gpd Designation - ASC3342**

HiBlow Model HP80- Linear- 2.0 amps / 76 watts / 3.9 CFM open flow  
SECOH EL80-17 - Linear - 1.8 amps / 131 watts / 4.6 CFM open flow  
GAST Model RV03 - Rotary – 3.0 amps / 120 watts / 3.8 CFM open flow

**Models AS750, AS750EZ**

**Aqua Safe® 750 gpd Designation - ASC3352**

SECOH Model EL100 - Linear - 2.5 amps / 174 watts / 5.3 CFM open flow  
GAST Model RV05 - Rotary – 3.0 amps / 120 watts / 4.8 CFM open flow  
Hiblow Model HP120- Linear- 2.1 amps/105 watts/5.6 CFM open flow

**Model AS1000, AS1000EZ**

**Aqua Safe® 1000 gpd Designation - ASC5082**

SECOH Model EL150 - Linear - 3.6 amps / 262 watts / 9.7 CFM open flow  
GAST Model 0823 - Rotary - 8.6 amps / 700 watts / 7.2 CFM open flow  
HiBlow Model HP150- Linear- 2.1 amps / 125 watts / 6.4 CFM open flow

**Model AS1500, AS1500EZ**

**Aqua Safe® 1500 gpd Designation - ASC7510**

HiBlow Model HP200- Linear- 4.3 amps / 225 watts / 8.3 CFM open flow  
GAST Model 1023 - Rotary - 10.0 amps / 950 watts / 10 CFM open flow  
SECOH Model EL200 - Linear - 5.2 amps / 350 watts / 11.6 CFM open flow

# GAST Spare Parts

## HP SERIES

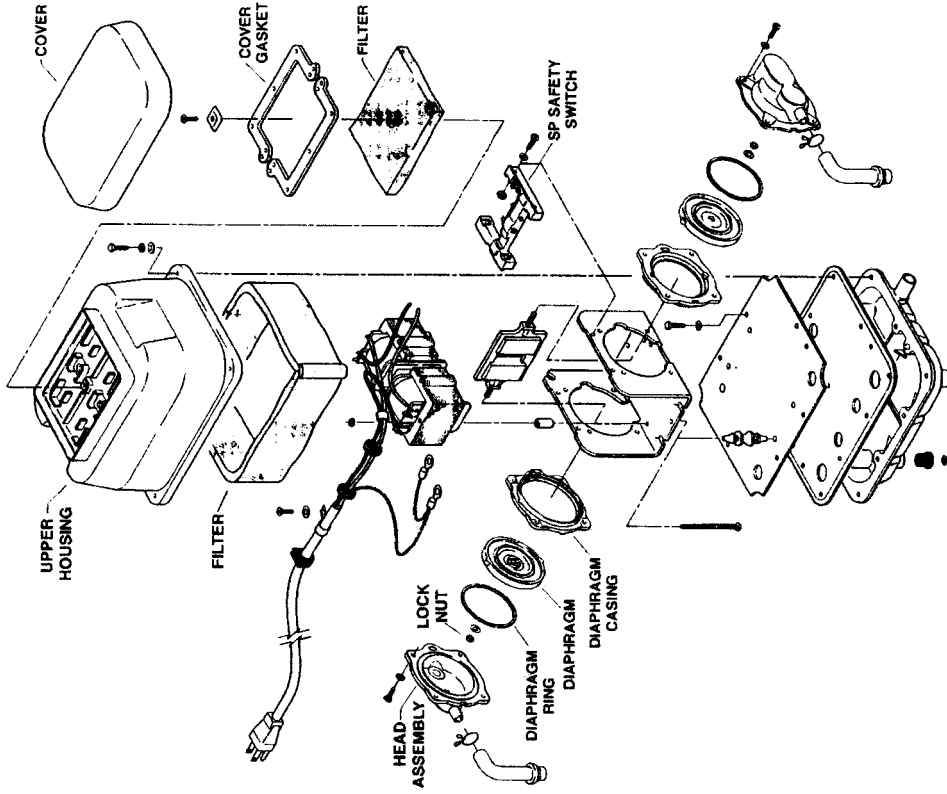

## GJL, GJH SERIES

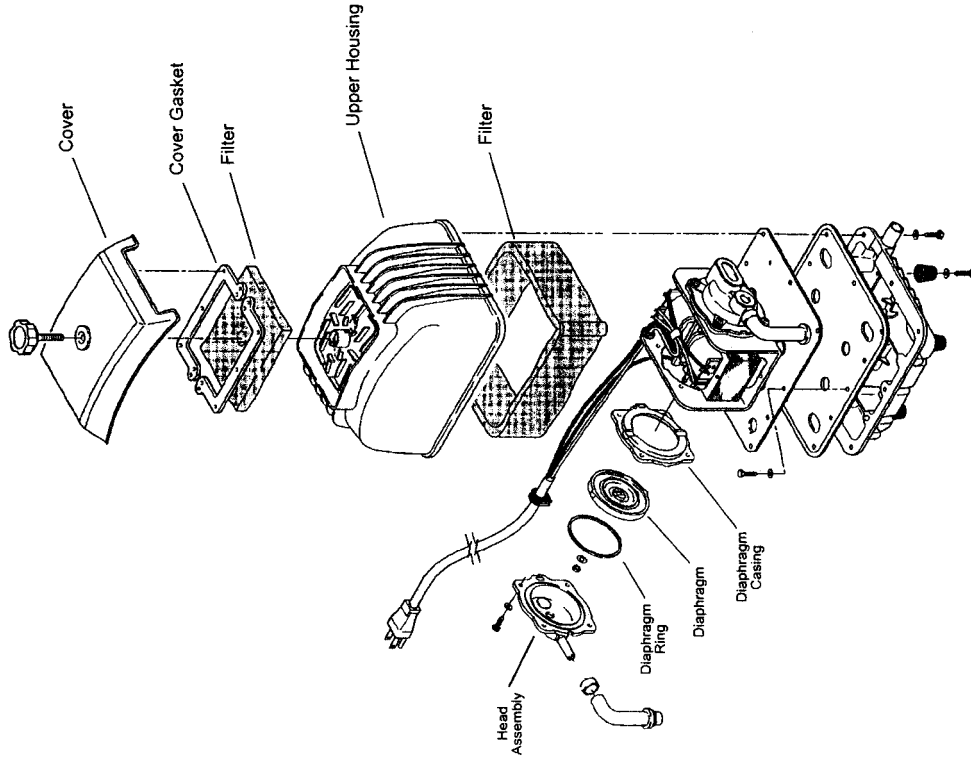

DESCRIPTION	80GJL	150GJH, 200GJH	HP100
FILTER PAD	K701	K702	K631
HEAD ASSEMBLY	K621	K711	K652
DIAPHRAGM ASSEMBLY	K620	K710	K653
SAFETY SWITCH BAR/SCREW	NA	K703	K654

## EXPLODED PRODUCT VIEW, PARTS & ORDERING INFORMATION

REF	DESCRIPTION	QTY	RV03-101	RV05-101
1	BODY	1	AK504	AK500
2 *	VANE	4	AH850A	AH850A
3	SHROUD	1	AK502B	AK502B
4	END PLATE	1	AK501	AK501
5 *	GASKET	1	AK521	AK521
6	MUFFLER BOX	1	AK519	AK519
7 *	O-RING	2	AK473	AK473
8 *	FELT	2	AK524	AK524
9	END CAP	2	AK510	AK510
10	END CAP FILTER ASSEMBLY	2	AK526	AK526
11	FILTER / MUFFLER	1	B343B	B343B
12	FOOT SUPPORT KIT	1	AC136	AC136
13	FELT SUPPORT	1	B347	B347
14 *	FELT FILTER	2	B344A	B344A
15	SCREEN CAP	1	AJ571	AJ571
16	ROTOR	1	AH775B	AH775B
17	TOLERANCE RING	1	AF105	AF105
	SERVICE KIT	1	K882	K882

\* Denotes parts included in the Service Kit. Parts listed are for stock models.

\*\* No Service Kit available, order parts separately. For specific OEM models, please consult the factory. When corresponding or ordering parts, please give complete model and serial numbers.

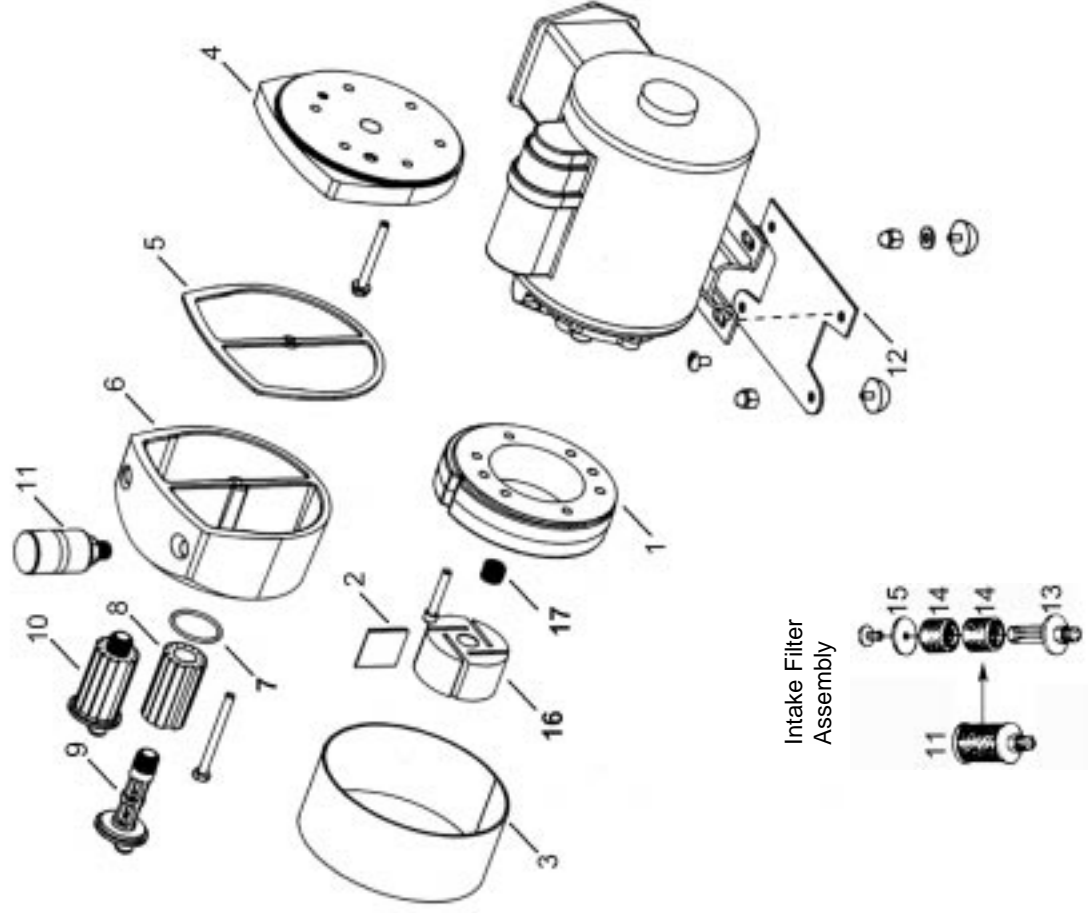



Ecological Tanks, Inc.  
Downsville, LA 71234

OWNER'S MANUAL  
**4" Submersible  
High-Pressure Effluent Pump**

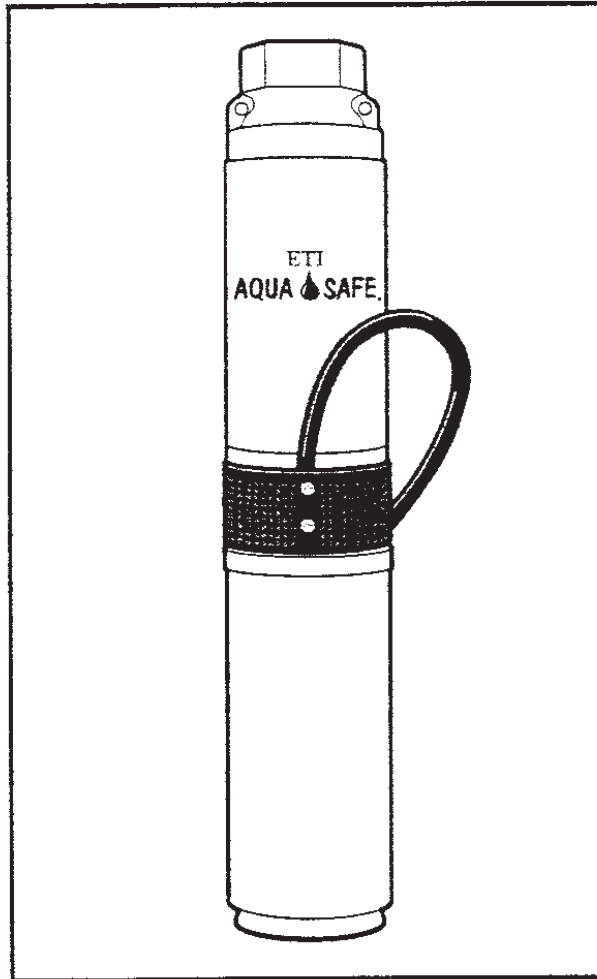



Installation/Operation/Parts  
*For further operating, installation, or maintenance assistance:*  
**Call 1-318-644-0397**

## TABLE OF CONTENTS

Safety Instructions .....	2
General .....	2
Electrical .....	2-3
Operation .....	3
Troubleshooting Guide .....	4
Warranty .....	4

Carefully read and follow all safety instructions in this manual or on pump.

 This is the safety alert symbol. When you see this symbol on your pump or in this manual, look for one of the following signal words and be alert to the potential for personal injury!



 **DANGER** DANGER warns about hazards that will cause serious personal injury, death or major property damage if ignored.

 **WARNING** WARNING warns about hazards that can cause serious personal injury, death or major property damage if ignored.

 **CAUTION** CAUTION warns about hazards that will or can cause minor personal injury or property damage if ignored.

The word **NOTICE** indicates special instructions which are important but not related to hazards.

To avoid serious or fatal personal injury and possible property damage, carefully read and follow the safety instructions.

-  **WARNING** Under certain conditions, submersible pumps can develop extremely high pressure. Install a pressure relief valve capable of passing entire pump flow at 75 PSI.  
 **Hazardous pressure**

 Do not allow pump, piping, or any other system component containing water to freeze. Freezing may damage system, leading to injury or flooding. Allowing pump or system components to freeze will void warranty.

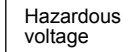
-  **WARNING** Can shock, burn or cause death. To avoid dangerous or fatal electric shock hazard, use pump only in an effluent system. **DO NOT** install pump in an open body of water ( a lake, swimming pool, etc.).  
 **Hazardous voltage**

 Install, ground and wire pump according to local and Canadian Electrical Code or National Electrical Code requirements that apply.

 Disconnect electrical power supply before installing or servicing pump.

 Make sure motor nameplate voltage and frequency match line voltage and frequency of power supply.

1. Install pump according to all plumbing, pump and well code requirements.
2. Install an all leg disconnect switch in the power supply near the pump.
3. Two-wire motors are equipped with automatic thermal overload protection which will open the circuit and stop the motor when a thermal overload (excessive heating) exists. When motor cools, overload will reset and motor will restart automatically. *This can cause the motor to start unexpectedly and without warning.*

## GENERAL

Inspect pump and motor for delivery damage. Report any damage immediately to shipping carrier or to Aqua Safe® immediately.

Have any installation, repair, or service work done by your Aqua Safe® dealer.

Never run pump dry.

**NOTE:** Install pump in the effluent or pumping chamber of vault — NOT in the sewage chamber. Pump is designed to pump filtered effluent or clear water only. It is not a sewage pump.

During system operation, pump must be submerged at all times.

Pipe joint compound can cause cracking in plastics. Use only teflon

tape when sealing joints in plastic pipe.

Warranty is void in the following conditions:

- Water is highly corrosive.
- If entrained gas or air present in water being pumped reduce the flow and cause cavitation (which can damage the pump).
- Pump has been operated with discharge valve closed (severe internal damage will result).

## ELECTRICAL

### WIRING/GROUNDING

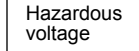
 **WARNING** Can shock, burn, or cause death. Permanently ground pump, motor and control box before connecting power supply to motor.  
 **Hazardous voltage**

Ground pump and motor in accordance with all codes and ordinances that apply. All wiring must meet National Electrical Code and Canadian Electrical Code (whichever applies). Use copper ground wire at least as large as wires carrying current to motor.

Motor is supplied with copper ground wire. Splice to copper conductor that matches motor wire size specified in Table 2. Use only copper wire for connections to pump.

Permanently ground pump and motor before connecting power cable to power supply. Connect ground wire to approved ground first, then connect to equipment being installed.

Do not ground to a gas supply line.

Float switches or any other approved motor control must match motor input in full load amperes.

For more information, contact your local code officials.

## INSTALLATION WIRING INSTRUCTIONS

### Single Phase, 2 Wire

2-Wire pumps have two power supply wires (Red/Black) and one ground wire (Green).

1. Fasten power supply wire leads securely to pump discharge section; leave 4-5" of slack in leads at this point. Securely fasten leads to plastic pipe within 6" of the pump discharge section.
2. Ground wire must be as large as wires supplying current to motor. Consult current National Electrical Code or Canadian Electrical Code (as applicable) and local codes for grounding information.
3. Use only submersible power supply wires supplied by pump manufacturer. When installing pump, secure supply wires to discharge pipe with Scotch #33 electrical tape. **DO NOT** damage pump wires.

**NOTICE:** To avoid dropping pump or damaging wires or splices, NEVER allow pump wires to support weight of pump.

## EFFLUENT APPLICATIONS

Effluent applications must meet the following:

 **WARNING** Risk of electrical shock. Do not remove cord and strain relief. Do not connect conduit to pump.

1. Only qualified personnel should install the pump and associated control equipment.
2. Vent sewage tank according to local code.
3. Do not install pump in any location classified as hazardous by National Electrical Code, ANSI/NFPA 70-1984.
4. These pumps are intended for permanent connection only. Provide strain relief at control box for power supply cord connection to box. All control components must be UL listed and suitable for end use application.

## PUMP INSTALLATION

1. Make sure that pump and motor are free to rotate by turning the shaft by hand.
2. To prevent dropping pump, lower it by the drop pipe, not by the cables. The electrical cables will not hold the pump weight.
3. Discharge outlet is 1-1/4" NPT threaded.

**NOTICE:** Pump discharge is left-hand thread into pump shell. If installing external check valve, hold discharge with pipe wrench to prevent loosening discharge in shell.

4. If pump is to be operated with an open discharge, a discharge valve *must be installed.* Before startup, open this valve about 1/3 open. Start pump. *Slowly* open valve until the desired flow rate is reached. Final setting *must* be within pump's recommended operating range.

## OPERATION

1. The pump must be submerged at all times during normal operation. **Do not run pump dry.**
2. Make sure that the float switches are set so that the pump stops before the pump runs dry or breaks suction. If necessary, adjust float switches to achieve this.
3. The motor bearings are lubricated internally. No maintenance is required or possible on the pump or the motor.

**Table 1: Recommended Fusing Data**  
60 Hz/1 Phase 2-Wire Cable

HP	Voltz/Hz/ Phase	Motor Winding Resistance Ohms	Max Load Amps	Locked Rotor Amps	Fuse Size Standard/ Dual Element
1/2	115/60/1	1.4-1.6	10.5	33.4	35/20

**Table 2: Power Supply Wire (Cable) Length in Feet**  
1 Phase, 2 Wire Cable, 60 Hz (Copper Wire Size - Service to motor)

Volts	HP	14 AWG	12 AWG	10 AWG	8 AWG	6 AWG	4 AWG	3 AWG	2 AWG	1 AWG	0 AWG
115	1/2	100	160	250	390	620	960	1190	1460	1780	2160

**NOTE:** Sizes given are for copper wire. For aluminum wire go two sizes larger (i.e., if table lists #12 copper wire, use #10 aluminum wire.)

## Motor Insulation Resistance Readings

Normal Ohm/Megohm readings for all motors, between all leads and ground. Set ohmmeter to 100K scale.

Condition of Motor and Leads	Ohm Value	Megohm Value
New motor, without power cable	20,000,000 (or more)	20.0
Used motor, which can be reinstalled in tank	10,000,000 (or more)	10.0
<b>Motor in Tank – Readings are Power Cable plus Motor</b>		
<i>Do not pull pump for these reasons:</i>		
New Motor	2,000,000 (or more)	2.0
Motor in reasonably good condition	500,000 to 2,000,000	0.5–2.0
Motor which may be damaged or have damaged power cable	20,000 to 500,000	0.02–0.5
<i>Pull pump; replace pump or cable:</i>		
Motor definitely damaged or with damaged power cable	10,000 to 20,000	0.01–0.02
Failed motor or power cable	Less than 10,000	0–0.01

## Important Electrical Grounding Information



**WARNING** Hazardous voltage. Can shock, burn, or kill. To reduce the risk of electrical shock during pump operation, ground and bond the pump and motor as follows:

- To reduce risk of electrical shock from metal parts of the assembly other than the pump, bond together all metal parts accessible at the tank top (including metal discharge pipe, metal tank top, and the like). Use a metal bonding conductor at least as large as the power cable conductors running down the well to the pump's motor.
- Clamp or weld (or both if necessary) this bonding conductor to the grounding means provided with the pump, which will be the equipment-grounding terminal, the grounding conductor on the

pump housing, or an equipment-grounding lead. The equipment-grounding lead, when provided, will be the conductor having green insulation; it may also have one or more yellow stripes.

- Ground the pump, motor, and any metallic conduit that carries power cable conductors. Ground these back to the service by connecting a copper conductor from the pump, motor, and conduit to the grounding screw provided within the supply-connection box wiring compartment. This conductor must be at least as large as the circuit conductors supplying the pump.

**Save these instructions.**

## TROUBLESHOOTING GUIDE

PROBLEM	CHECK	CORRECTIVE ACTION
Motor will not start but fuses do not blow No voltage.	No voltage at disconnect switch. Electrical cable bad.	Replace blown fuses or bad cable, reset circuit breakers. Consult licensed electrician or serviceman.
Fuses blow or overload protector trips when motor starts Wrong size fuse, time delay fuse, or circuit breaker. Wire size too small. Low or high voltage. Pump or motor stuck or binding. Power supply wires or motor leads grounded, shorted, or open.	Check fuse or circuit breaker size against chart, Page 2.  Check wire size against chart, Page 3. Check that line voltage is within $\pm 10\%$ of nameplate rated voltage while motor is running. Check for locked shaft in pump.  Consult licensed electrician or qualified serviceman.	Install correct fuse, time delay fuse, or circuit breaker.  Install correct size wire. If voltage variation is greater than $\pm 10\%$ , call power company or local hydro authority to adjust voltage. If necessary, pull pump (make all possible above ground checks first). If pump is locked, replace it. Clean tank of all sand, lime, and solids before reinstalling pump. Have a qualified serviceman or electrician make necessary cable repairs.
Fuses blow or overload protector trips when motor is running Low or high voltage. High ambient (atmospheric) temperature. Wire size too small.	Check that line voltage is within $\pm 10\%$ of rated nameplate voltage while motor is running. Check temperature of tank Check wire size against chart, Page 3.	If voltage variation is more than $\pm 10\%$ , call power company to adjust voltage. Protect tank from direct sunlight. Install correct wire size.
Pump starts too frequently Leaks in system. Level switch. Check valves leaking.	Check plumbing for leaks. Check for defective switch or switch out of adjustment. Make sure check valves are not leaking back.	Re-adjust or replace level switch. Replace check valves if necessary.
Little or no water delivered Check valve stuck. Low voltage.  Plugged intake screen. Check valve at pump discharge stuck. Worn impellers and diffusers. Pump doesn't develop enough pressure ("head"). Plugged impellers.	Examine valve. Check voltage at circuit breaker with pump running. Check incoming wire size and power supply wire size against chart, Page 3. Pull pump and check condition of screen. Pull pump and examine check valve. Make sure system is clear of obstructions and pump is in solid water and operating normally. Check pump curve against operating conditions. Pull pump.	If stuck, free valve. Install larger wire from meter to circuit breaker. Install larger wire from circuit breaker to pump. If necessary, have power company raise supply voltage. Clean or replace as necessary. Free check valve. Replace pump. Replace pump with "higher head" pump. Replace pump.

## INITIAL SERVICE POLICY

The local dealer/installer from whom you purchased your **Aqua Safe®** wastewater treatment plant is responsible for routine inspections for the first two years from the original date of installation. The plant will be checked for proper operation at each inspection. If a problem exists, service shall be performed at no charge to the owner unless the required maintenance is not warranty related. These service call/inspections shall include at least four inspections over the two year period and shall include the following:

1. Adjustment of the electrical control, if applicable, and servicing of the mechanical component parts to ensure proper function.
2. An effluent quality inspection consisting of a visual check for color, turbidity, scum overflow, and an examination for odors.
3. Immediate notification to the owner/warrantee in writing of any improper observation which cannot readily be repaired. This notification will or shall advise said owner of the problem, if it is covered by warranty and estimated date for correction of said problem.

Pumping of sludge build up from the treatment plant, if necessary, **IS NOT INCLUDED** in the initial service policy.

An annually renewable service policy affording the same coverage as the initial service policy is available. Consult your local dealer for pricing information.

## LIMITED WARRANTY

**Ecological Tanks, Inc., Aqua Safe®** (hereinafter identified as manufacturer) warrants each **Aqua Safe®** wastewater treatment plant to be free from defects in materials and workmanship from the date of installation by an manufacturer authorized dealer/installer for the following periods: Manufacturer warrants system aerator for a limited, prorated five (5) year period as follows: First two (2) years - 100%; 2<sup>nd</sup> to 3<sup>rd</sup> year - 75%; 3<sup>rd</sup> to 4<sup>th</sup> year - 50%; 4<sup>th</sup> to 5<sup>th</sup> year - 25% of manufacturer's list price. Third, fourth, and fifth year limited, prorated portion of this warranty applies only if the system owner carries a continuous maintenance policy provided by a manufacturer authorized dealer/installer and **proof** is provided with the return. Manufacturer warrants fiberglass tanks, for a limited period of (5) years, to be free from defects in material and workmanship. Electrical controls, float switches, and application pumps are warranted for two (2) years. Concrete tanks are limited to (2) years from date of installation. When properly installed and registered with the manufacturer, the manufacturer's sole obligation under this **limited warranty** is as follows:

To repair or exchange any components, F.O.B. factory, that in the manufacturer's judgment is defective, provided that said component part has been paid for and is returned through an authorized dealer, prepaid. The warrantee must specify the nature of the defect in writing to the manufacturer. The **limited warranty** makes no provision for any informal dispute settlement agreement.

The **limited warranty** does not cover any **Aqua Safe®** wastewater treatment plant that has not been properly installed, damaged due to altered or improper wiring or overload protection, flooded by any external means, disassembled by any unauthorized person, filled with anything other than normal household wastewater or damaged by an act of nature. The **limited warranty** does not cover damages or defects caused by ants, insects or rodents to any component part of the **Aqua Safe®** wastewater treatment plant.

No warranty is made as to the field performance of any system. The limited warranty applies only to the **Aqua Safe®** wastewater treatment plant itself and does not include any of the purchaser's plumbing, drainage and/or disposal system, house wiring or the installation of the **Aqua Safe®** treatment plant.

The manufacturer reserves the right to replace any component part covered under this **limited warranty** with a component part, which in the manufacturer's judgment, is equivalent to the part being replaced. The manufacturer claims no responsibility for any delays or damages caused by defective components or materials which cause losses incurred by interruption of service or for repairs or replacement components parts covered by the **limited warranty**.

**MANUFACTURER'S WARRANTY REGISTRATION CERTIFICATE**

It is the **authorized dealer/installer's responsibility** to fill out the registration certificate and mail it **within 30 days** of installation to the address below. The owner/purchaser should verify that this is done to insure proper registration for warranty purposes.

**ECOLOGICAL TANKS, INC.**  
**2247 HIGHWAY 151 NORTH, DOWNSVILLE, LA 71234**  
**OFFICE: 318-644-0397 FAX: 318-644-7257**

**PLEASE PRINT**

**AQUA SAFE® PURCHASER'S RECORD**

**Serial#** \_\_\_\_\_ **Model#** \_\_\_\_\_ **Installation Date** \_\_\_\_\_  
**Installer's Name** \_\_\_\_\_  
**Mailing Address** \_\_\_\_\_  
\_\_\_\_\_ **Phone** \_\_\_\_\_

---

**AQUA SAFE® INSTALLER'S RECORD**

**Serial#** \_\_\_\_\_ **Model#** \_\_\_\_\_ **Installation Date** \_\_\_\_\_  
**Owner's Name** \_\_\_\_\_  
**Physical Address/City** \_\_\_\_\_  
\_\_\_\_\_ **Phone** \_\_\_\_\_

---

**AQUA SAFE® REGISTRATION CERTIFICATE**  
**(Must be returned to manufacturer)**

**Serial#** \_\_\_\_\_ **Model#** \_\_\_\_\_ **Installation Date** \_\_\_\_\_  
**Owner's Name** \_\_\_\_\_  
**Physical Address/City** \_\_\_\_\_  
\_\_\_\_\_ **Phone** \_\_\_\_\_  
**Dealer's Name** \_\_\_\_\_  
**Mailing Address** \_\_\_\_\_  
\_\_\_\_\_ **Phone** \_\_\_\_\_  
**Installer's Name** \_\_\_\_\_  
**Mailing Address** \_\_\_\_\_  
\_\_\_\_\_ **Phone** \_\_\_\_\_